

EXPERT NEWS™

2023
N.01

ENGINE PAG.1-9
CHASSIS PAG.10-20
GARAGE PAG.21-24

G WRENCHES FOR NOX AND PARTICULATE MATTER SENSORS 14/17/19/22/24 MM

NEW

14 MM 17 MM 19 MM
22 MM 24 MM



- Allows professional disassembly and assembly of exhaust particle NOX sensors.
- The closed 6-point profile allows very high loosening torques, especially with an extremely locked coupling.
- The special design of the special socket wrench prevents slipping and damage of the wrench profile on the sensor.
- The connection cable is led to the side of the wrench and is therefore protected from cuts and incisions.

Technical data

- Total length 85 mm
- 1/2" guide



Q.TY	COMPONENTS	TECHNICAL DATA
1 x	Socket wrench	24 mm
1 x	Socket wrench	32 mm
1 x	Socket adapter	14 mm
1 x	Socket adapter	17 mm

1 x	Socket adapter	19 mm
1 x	Socket adapter	22 mm
1 x	Socket adapter	24 mm



GO CODE **700**
with 7 pcs. 2,5 Kg

G 1/2" LAMBDA PROBE SOCKET, GROOVED 24MM

- It allows the disassembly and assembly of the lambda probe, NOX and exhaust particulate matter sensors.



Use

- Its double 1/2 inch square drive allows quick repositioning.
- It can also be operated via the large external hexagon.
- The flat and grooved design ensures good accessibility and excellent hold..



GO CODE **694**
with 1 pcs. 0,24 Kg

G MALE SET AND MAGNETIC MALE HOLDER ADAPTER M12X1.25

- The set consists of a male and a magnetic male holder adapter with locking ball for ratchet wrench.

Technical data

- 7,2 mm magnetic adapter



Use

- The operation of the males can be carried out by means of a screwdriver or socket wrench.



GO CODE **956**
with 2 pcs. 0,15 Kg

G NOX SENSOR HOLE THREAD RESTORER MALE M20X1.5

- This tool allows you to professionally restore the thread of the NOX sensor hole without damaging the exhaust system.

UNIVERSAL

Technical data

- Square drive: SW 13 mm
- Length: 50 mm
- Tensioning grooves: 6
- Material: HSCO

APPLICATION
universally used for light and heavy diesel engines

GO CODE **958**
with 1 pcs. 0,9 Kg



G 1/2" LAMBDA PROBE SOCKET, GROOVED 22MM

- It allows the disassembly and assembly of the lambda probe, NOX and exhaust particulate matter sensors.



Use

- Its double 1/2 inch square drive allows quick repositioning.
- It can also be operated via the large external hexagon.
- The flat and grooved design ensures good accessibility and excellent hold..



GO CODE **695**
with 1 pcs. 0,24 Kg

G MALE SET AND MAGNETIC MALE HOLDER ADAPTER M14X1.5

- The set consists of a male and a magnetic male holder adapter with locking ball for ratchet wrench.

Technical data

- 9,2 mm magnetic adapter



Use

- The operation of the males can be carried out by means of a screwdriver or socket wrench.



GO CODE **957**
with 2 pcs. 0,15 Kg

G NOX SENSOR HOLE THREAD RESTORER MALE M22X1.5

- This tool allows you to professionally restore the thread of the NOX sensor hole without damaging the exhaust system.

UNIVERSAL

Technical data

- Square drive: SW 13 mm
- Length: 50 mm
- Tensioning grooves: 6
- Material: HSCO

APPLICATION
universally used for light and heavy diesel engines

GO CODE **959**
with 1 pcs. 0,9 Kg



G QUICK-FIT PLIER

UNIVERSAL

- The flexible quick-fit plier with sleeve has been designed to open quick connectors with double locking (i.e. ARaymond) without damaging them.



Plier material	Hardened steel
Plier length	250 mm
Sleeve length	590 mm
Total length	670 mm

GO CODE **805**
T with 1 pcs. kg 0,5 kg

G HOSE CLAMPS PLIER (MUBEA AND NORMA)

UNIVERSAL

This flexible quick-fit plier with reinforced sleeve is used to open and close self-arresting lock hose clamps.



Plier material	Hardened steel
Plier length	260 mm
Sleeve length	730 mm

APPLICATION	HOSE CLAMPS TYPE	Ø	WIDTH
	MUBEA	Ø18-54mm	12+15mm
	NORMA		

GO CODE **809**
T with 1 pcs. kg 0,4 kg

G PLIERS FOR REMOVING FUEL LINES WITH QUICK COUPLERS

UNIVERSAL

Technical data

- Total length 270mm
- Length of the swivel head 50 mm
- Finger pliers Ø 4.5 mm / conical



ARAYMOND QUICK CONNECTOR

Angled Straight



Quick couplings for VAG fuel



- These special pliers let you open quick connectors (double click).
- The pliers have a swivelling and adjustable head that can also be adapted to quick couplings for VAG fuel with very small connectors and positioned in inaccessible areas.

APPLICATION
Universal for fuel and AdBlue connectors, for example on Audi, BMW, Chrysler, Fiat, Mercedes, Opel, Peugeot, Renault, Seat, Skoda, VW etc.

GO CODE **828**
T with 1 pcs. kg 0,35 Kg

G PLIERS FOR HOSE CLAMPS

- Pliers to move the exhaust straps apart and keep them open when changing the muffler.
- For mounting and dismounting reusable muffler straps with edging.



+ **PLUS**
4 stop levels mean clamping is not lost during gripping.
Guide sleeves on plier tips prevent slippage.

Technical data

- 4 locking positions
- Tightening from 20 - 60 mm
- Coated handle
- With locking
- Automatic opening

APPLICATION
Citroën, Peugeot e Renault

GO CODE **685**
T with 1 pcs. kg 0,45 Kg

G RELEASE PLIERS FOR ELECTRICAL CONNECTIONS SHORT GRIPPERS

- These special pliers unlock the locking tabs on the electrical connectors, component connectors and wiring connectors.



Technical data

- Overall length: 175 mm.
- Grip arm length 60 mm
- Opening width max. 45 mm

GO CODE **690**
T with 1 pcs. kg 0,72 Kg

G RELEASE PLIERS FOR ELECTRICAL CONNECTIONS LONG GRIPPERS

- These special pliers unlock the locking tabs on the electrical connectors, component connectors and wiring connectors.



Technical data

- Overall length 205 mm
- Grip arm length 90 mm
- Opening width max. 65 mm

GO CODE **691**
T with 1 pcs. kg 0,65 Kg

G CONNECTOR REMOVAL TOOL

- For safe and proper removing of most VAG push & pull connectors e.g. electrical connector on mass air flow sensor (MAF), pressure sensor (MAP), ignition coil pack, headlight, fog light, level sensor, etc.

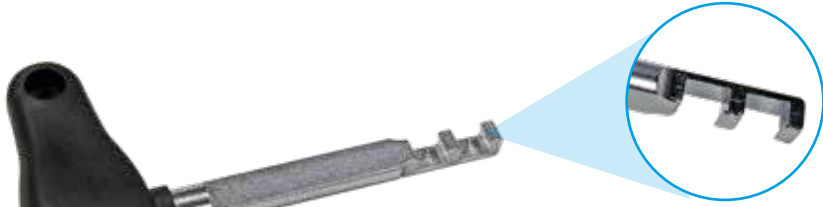

APPLICATION
designed specifically for removing connectors and releasing terminals of the VW Group vehicles

GO CODE **693**
with 1 pcs. 0,7 Kg



G PLIERS FOR EAR CLAMPS

UNIVERSAL

- For operations on particularly difficult to reach clamps on sleeves and hoses.



+ **PLUS**
What's special about these pliers is the lateral working method!



Technical data
• Length 240 mm

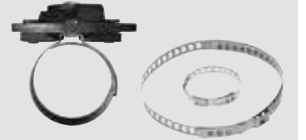

APPLICATION
Fuel lines, radiator hoses, steering cowls, axle cowls, etc.



GO CODE **797**
with 1 pcs. 0,34 Kg

G HENN® CLAMPS TOOL REMOVAL

UNIVERSAL



- Special tool to release/loosen the Henn® clamps, which are used in the automotive sector on the cooling system water pipes and in the radiators



Plier material Special steel
Plier length 75 mm
Plier rotation 90°

APPLICATION
Universal use on vehicles – SUVs – Vans

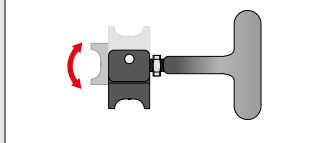

GO CODE **810**
with 1 pcs. 0,15 kg

G TOOL FOR INSTALLING WATER PUMP STRETCH BELT WITHOUT BELT TIGHTENER

OPEL | PSA



- Tool for installing water pump stretch belt without belt tightener. For use for PSA and Opel group vehicles engines 1.0 - 1.2.



APPLICATION			
BRAND	MODEL	ENGINE	ENGINE CODE
Peugeot	108, 208, 301, 308, 408, 2008, 3008, 5008, Partner	3 cilindri 1.0L/1.2L	EN-521122
Citroën	C1, C2, C3 Picasso, C3 Aircross, C4, C4 Picasso, C4 Cactus, C-Elysee, Berlingo, DS 3, DS 4, DS 4S, DS 5LS		
Vauxhall/Opel	Crossland X		

GO CODE **916**
with 1 pcs. 0,10 Kg

G AUXILIARY BELT TENSIONER TOOL SET

PSA

- Kit for tensioning the elastic and flat belts of the auxiliary parts of the PSA group vehicles.
- The special rectangular adapters ensure a perfect grip on the vehicle parts, and can be coupled to the most common wrenches on the market, making practical and quick the assembly and disassembly process of the belts on the auxiliary parts pulley



APPLICATION			
BRAND	ENGINE	ENGINE CODE	OEM CODE
CITROËN	1.4; 1.5; 1.6; 2.0; 2.2L	DV4TD; DW10FD; T3JA; W16D16; DV4TED4; UBGA; TZJA; 9HZ; DV6TED4; XVJB; AEDA; D4164T; DV6ATED4; HHJC; G8DC; 2WZ-TV ecc. Adatto anche per motori DW10 e DW12	OE PZ410-G0109-90
FORD			
MAZDA			
MINI			
PEUGEOT			
TOYOTA			
VOLVO			

COMPONENTS		
	OEM CODE	REF.
1 x Basic connection adapter	OE 01099-A	1
1 x 8.7 mm automatic tensioner adapter	OE 01099-B1	2
1 x 10 mm automatic tensioner adapter	OE 01099-B2	3
1 x SW15 double hex adapter	OE-01099-C	4
1 x SW15 Hex adapter x square 1/2"	OE-01099-D	5

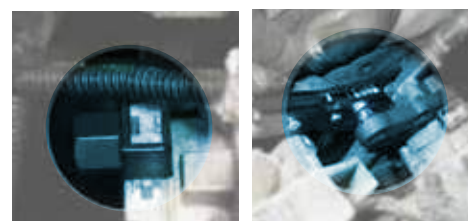

GO CODE **924**
with 5 pcs. 0,3 Kg

G AIR CONDITION BELT INSTALLATION TOOL

BMW N62 | MINI W17

- For installation of stretch belts (drive belts without tensioner)

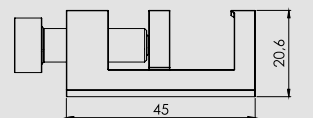
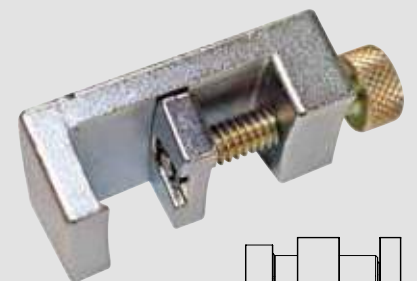

APPLICATION
suitable for stretching belts on BMW N62 (V8) (2004-2006) and MINI W17 (Diesel)

APPLICATION		
BRAND	APPLICATION	OEM
Mini	To be used as OEM2	64 1 040
BMW	To be used as OEM1	



GO CODE **919**
with 1 pcs. 0,10 Kg

G OIL FILTER WRENCH

- Suitable for assembly/ disassembly of oil filters.
- The toothed jaws ensure an optimal grip on the oil filter.
- This wrench allows to work perpendicularly without damaging the thread on which the oil filter is screwed down. The wrench "fastens" to the filter; therefore, it may be used whenever the working area is much reduced.



PLUS
Automatic adjustment with selflocking effect (via spring mechanism).

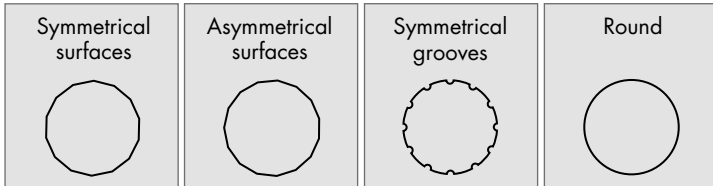

CODE	Ø (mm)	HEIGHT (mm)	□	COMP.	WEIGHT
GO 681	60-80	40	1/2" SW21	1 pcs	0,94 Kg
GO 676	80-100	50	1/2" SW22	1 pcs	0,94 Kg

G + UPGRADE OPTION + EXTENSIONS FOR ADJUSTABLE OIL FILTER WRENCH **NEW**

60-80MM

- Used in combination with the universal oil filter wrench **GO681**.
- The set consists of two half-shells (toothed on the inside), which can be mounted and secured directly on the jaws of the filter wrench.

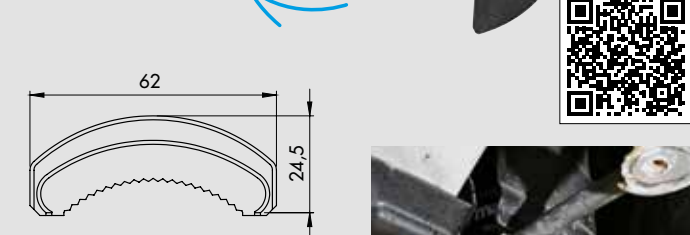
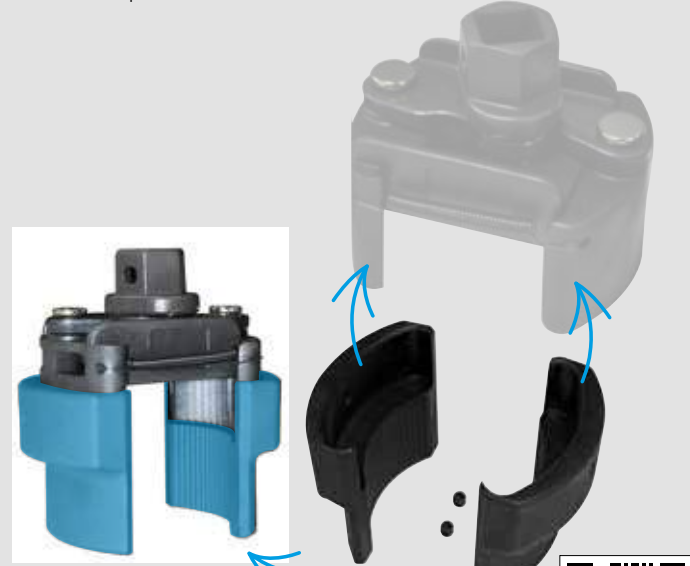

GO CODE **684**
T with 4 pcs. Kg 0,4 Kg

G OIL FILTER WRENCH KIT



- The oil filter wrench is indicated where filters are difficult to remove, since the sealing gaskets, often, are stick together.
- These wrenches allow to operate avoiding damages to the thread on which the oil/diesel filter is screwed.

N.	SIDES	DIM.	OEM FILTER CODE	BRAND
N.3	6 SIDES	66,5 (mm)	P4025 (0451104025)	DACIA, NISSAN, RENAULT
N.4	14 SIDES	74,4 (mm)	P7078 (F026407078)	FORD, VOLVO
			P3111 (0451103111)	ALFA ROMEO, FIAT
N.8	14 SIDES	64 (mm)	P3318 (0451103318)	PEUGEOT, AUDI
			P2028 (0986452028)	DAIHATSU, TOYOTA
N.10	12 SIDES	76,8 (mm)	P3355 (0451103355)	CHEVROLET, CITROEN, FIAT, LANCIA, OPEL, PEUGEOT, SUZUKI, TOYOTA
			P3336 (0451103336)	ALFA ROMEO, DACIA, JEEP MITSUBISHI, NISSAN, OPEL, PEUGEOT, RENAULT, SUZUKI
			P7072 (F026407022)	DACIA, HONDA, NISSAN, OPEL, RENAULT, SUZUKI, SMART
			P3300 (0451103300)	ALFA ROMEO, FIAT, LANCIA
N.23	14 SIDES	66,8 (mm)	P2041 (0986452041)	ALFA ROMEO

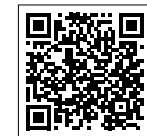

GO CODE **662**
T with 5 pcs. Kg 1,5 Kg

G OIL FILTER WRENCH

TOYOTA

DAIHATSU



APPLICATION:

Charmant, Cuore, Carina, Picnic, Camry, Starlet, Celica, MR2, Altezza, bB, VVish, Tercel, Harrier, LiteAce, Echo, Corona, Paseo, Avensis, iQ, RAV4, Vios, Auris, Aygo, C-CHR, Hilux, Prius, Yaris, Corolla,



N.	SIDES	DIMENSION	OEM FILTER CODE	BRAND
N. 8	14 SIDES	64 (mm)	P2028 (0986452028)	DAIHATSU, TOYOTA

GO CODE **623**
T with 1 pcs. Kg 0,2 Kg



G OIL FILTER WRENCH

VOLVO



APPLICATION:

S60 XC/S60/V60 (from 2011), S80 (from 2007), S90/V90 (from 2017), V40 (from 2013), V40 XC/V60 XC/V70 (from 2008), V70/XC70 (from 2008), XC60/XC70 (from 2008), XC90 (from 2016)



N.	SIDES	INTERNAL DIMENSION	OEM FILTER CODE	BRAND
N.45	16 SIDES	86 (mm)	OEM 9997499	VOLVO



GO CODE **674**
T with 1 pcs. Kg 0,4 Kg

G OIL FILTER WRENCH

UNIVERSAL



N.	SIDES	DIMENSION	OEM FILTER CODE	BRAND
N.10	12 SIDES	76,8 (mm)	P3355 (0451103355)	CHEVROLET, CITROEN, FIAT, LANCIA, OPEL, PEUGEOT, SUZUKI, TOYOTA
			P3336 (0451103336)	ALFA ROMEO, DACIA, JEEP MITSUBISHI, NISSAN, OPEL, PEUGEOT, RENAULT, SUZUKI
			P7072 (F026407022)	DACIA, HONDA, NISSAN, OPEL, RENAULT, SUZUKI, SMART
			P3300 (0451103300)	ALFA ROMEO, FIAT, LANCIA

GO CODE **624**
T with 1 pcs. Kg 0,2 Kg



G OIL FILTER WRENCH

UNIVERSAL



APPLICATION:

B-Max, C-Max, Ecosport, Fiesta, Focus, Fusion, Galaxy, Grand, KA+, Kuga, Mondeo, Puma, S-Max, Tourneo, Transit, 121 III Hatchback, 2 Hatchback, C30, S40, S60, S80, V40, V50, V60, V70, 145, 146, 156, Expert I, Expert I Van, Expert I Camion



N.	SIDES	DIMENSION	OEM FILTER CODE	BRAND
N.4	14 SIDES	74,4 (mm)	P7078 (F026407078)	FORD, VOLVO
			P3111 (0451103111)	ALFA ROMEO, FIAT
			P3318 (0451103318)	PEUGEOT, AUDI

GO CODE **621**
T with 1 pcs. Kg 0,2 Kg

G SET OF SPECIAL WRENCHES FOR PLASTIC OIL DRAIN PLUGS

- This set contains the most common special socket wrenches for plastic oil drain plugs.
- Precise fit profile allows for undamaged loosening and tightening according to manufacturer's specifications.
- Includes practical T-handle key with double internal 3/8 inch guide x 6 external SW17 sides.

COMPONENTS	
1 x	Socket wrench with 3 drivers
1 x	External Hex Socket Wrench
1 x	External Socket Wrench Slot
1 x	Internal Double Socket Wrench Slot
1 x	3/8" Square T-handle Wrench



Screw models



APPLICATION
BRAND
Ford/Peugeot/Citroen/Lincoln/Opel/
Vauxhall Toyota/Mercedes/BMW/
VW/Seat/Skoda/Seat/Porsche

GO CODE **688**
with 5 pcs. 0,25 Kg

G DRIVE SHAFT DISASSEMBLY TOOL

UNIVERSAL

- Designed to allow quick and safe removal of transmission-side drive shafts.
- Fits perfectly between gearbox and driveshaft for optimum contact and leverage on a wide range of vehicles including Ford, Volvo, Renault, Mazda and more

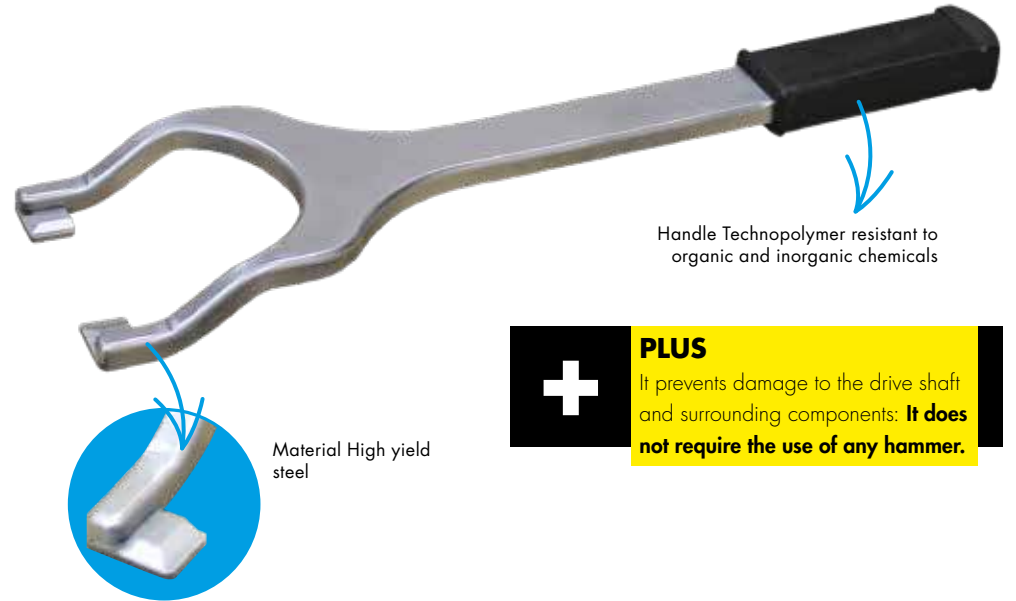

+ **PLUS**
It prevents damage to the drive shaft and surrounding components: **It does not require the use of any hammer.**

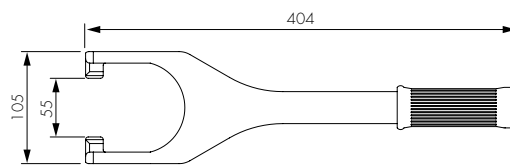

GO CODE **069**
with 1 pcs. 1,2 Kg



G CONICAL PRESSURE FORK TO SEPARATE AND MOUNT

L=360MM



- Practical auxiliary tools for versatile use in the automotive sector (e.g. disassembly of clutch/gearbox, etc.)
- Applications e.g.: to leverage on vehicle panels and body parts, axle parts, gearbox rods, exhaust support, housings etc.
- To quickly unscrew the heads of the transverse tie rods, control levers, etc.
- Also suitable for testing bearings and articulated joints.

Technical data

- Internal fork width: 25 mm
- External fork width: 80 mm
- Fork Length: 110 mm

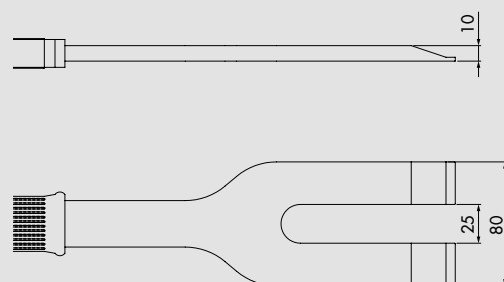

GO CODE **946**
with 1 pcs. 0,7 Kg

G CONICAL PRESSURE FORK TO SEPARATE AND MOUNT

L=320MM



- Practical auxiliary tools for versatile use in the automotive sector (e.g. disassembly of clutch/gearbox, etc.)
- Applications e.g.: to leverage on vehicle panels and body parts, axle parts, gearbox rods, exhaust support, housings etc.
- To quickly unscrew the heads of the transverse tie rods, control levers, etc.
- Also suitable for testing bearings and articulated joints.

Technical data

- Internal fork width: 15 mm
- External fork width: 40 mm
- Fork Length: 70

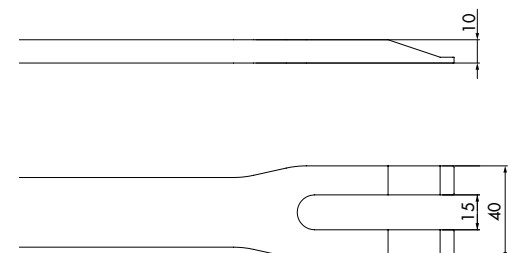

GO CODE **947**
with 1 pcs. 0,7 Kg



**PROFESSIONAL KIT FOR EXTRACTION/
INTRODUCTION LOCKED INJECTORS**

BOSCH DELPHI DENSO SIEMENS
CONTINENTAL UNIVERSAL

- Tool set designed to disassembly stuck Common Rail (CR) injectors.
- Composed by a universal bridge patented system, capable of adapting to the majority of engines on the market, as such adjustable in height, incline and extension. Designed in order to operate directly on the vehicle and in narrow spaces.
- The injector is removed from the cylinder head through the mechanical system with bearing.
- The 20 T hydraulic cylinder Art. **GO1020** or the mechadraulic cylinder Art. **GO1015** (not included), can be purchased in addition of this kit.
- It is possible to integrate this set with a vibration tool for the injector's extraction, Art. **GO490** (not included).

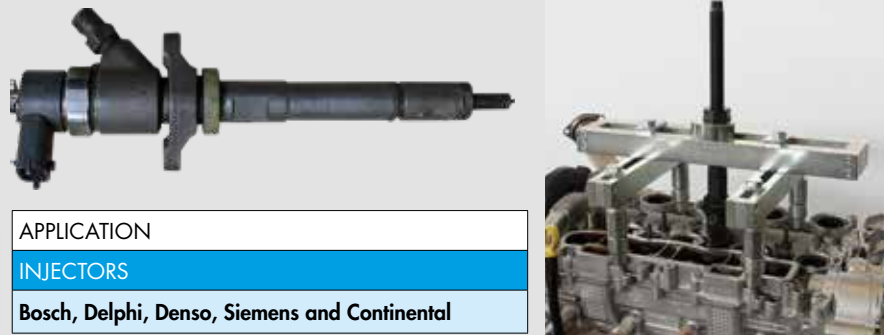

GO CODE **405**
with 43 pcs. 21,3 Kg
§ **PATENTED**

APPLICATION
INJECTORS
Bosch, Delphi, Denso, Siemens and Continental

+ **INCLUDED**
Lubricating grease to be used with threaded bars, nuts, etc...



UPGRADE OPTION
MECHADRAULIC CYLINDER 12 TON



Technical data

- Force: 12ton
- Stroke: 8 mm
- Dim.: Ø80x260x45 mm
- Pressure: max. 700 Bar
- Driving torque: 56Nm
- Hole: Ø21,5 mm
- Adaptors: M10/M12/ M14/M16/M18
- Weight: 1,65 Kg
- Grease temperature range of use: from -25°C to 80°C
- Material: aluminium



GO CODE **1015**
with 8 pcs. 1,8 Kg
§ **PATENTED**



UPGRADE OPTION
VIBROFIGHTER CE

- This tool, through vibrations and pulses, acts directly on the tie rod, allowing the removal of highly tightened injectors.
- Thanks to the adjusting valve, the operator can settle the intensity of the pulse.



GO CODE **490**
with 6 pcs. 3 Kg
§ **PATENTED**



PIEZO INJECTOR EXTRACTOR

PIEZO



- Complete tool for removing piezoelectric injectors with M14 injection line socket.
- Good impact applied with elevated loosening effect.
- Loosen about 80% of all stuck injectors. This allows a significant saving in terms of time and cost, avoiding, where possible, the risk of sending the injectors to be rectified.

APPLICATION
INJECTOR
Renault, Nissan, Opel and other manufacturers' diesel engines



GO CODE **559**
with 4 pcs. 1,8 Kg



BOSCH INJECTOR EXTRACTOR

BOSCH DUCATO 3.0D



- Complete tool for the removal of Bosch piezo injectors.
- The injector is held firmly on the injection line thread and in the clamping claw support and it is pulled out with a sledgehammer.
- Removal is carried out without partial disassembly and this ensures that the injector can be reused



GO CODE **561**
with 4 pcs. 2 Kg



PIEZO INJECTOR EXTRACTOR

M18X1,5 BOSCH



- Complete tool for the removal of Bosch magnetic injectors.
- The half-shells of the tool head are positioned directly under the screw ring of the injector electrical connection. The locking sleeve with window provides a non-slip grip.
- Universal for diesel engines of many manufacturers.

Technical data

- Connection M18x1.5 internal thread



GO CODE **563**
with 4 pcs. 3 Kg

+ **PLUS**
Removal is carried out without partial disassembly and this ensures that the injector can be reused.

APPLICATION
INJECTOR
Universal for multi-brand diesel engines

APPLICATION			
BRAND	MODEL	ENGINE	INJECTOR CODE
Fiat	Ducato	3.0 L Diesel from 2006	0445116059 0445116019
	Iveco Daily	2.3 L from 2011 to 2014 3.0 L Diesel from 2007	
Citroen	Jumper	3.0 L HDI from 2010	
Peugeot	Boxer	3.0 L HDI from 2010	

G SLIDE HAMMER INJECTOR SET WITH CR ADAPTERS

BOSCH
DENSO

SIEMENS

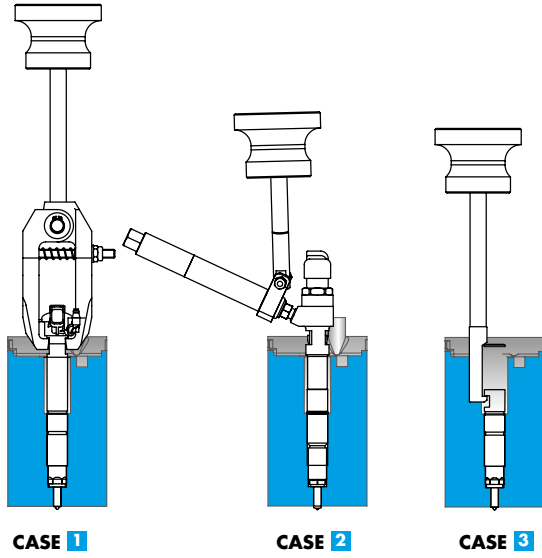

PLUS
This operation may be carried out without disassembling the injector head.

- New adapters M12x1.5 and M14x1.5 for CR connector.
- Extractor for injectors for professional mechanics, car-repair garages or car repair shops. This kit allows injector removal with three distinct procedures:

- 1 Using the pliers with holding arms perfectly fitting to the shape of the injector.
- 2 Using the articulated joint adapter and the pivot, that has to be screwed to the fitting of the Common Rail duct.
- 3 Use on Pump Düse injectors.



GO CODE **449**
with 9 pcs. 5 Kg

G DIESEL INJECTOR LINE SOCKET WRENCH

- Set of 6 open-ended polygonal wrenches for mounting and dismounting injector pipe fittings
- Polygonal attachment



COMPONENTS	SIZES
1 x wrench	12 mm
1 x wrench	14 mm
1 x wrench	16 mm
1 x wrench	17 mm
1 x wrench	18 mm
1 x wrench	19 mm



GO CODE **918**
with 6 pcs. 1 Kg

G BOSCH ADAPTOR



APPLICATION
Double fixing

COMPONENTS	DIMENSIONS
1 x pin	M17x1 - M18x1.5
1 x bush	M27x0.75

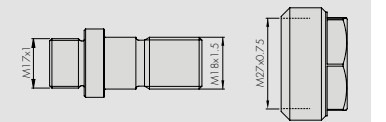

GO CODE **493**
with 2 pcs. 0,3 Kg

G + UPGRADE OPTION + 20T HYDRAULIC CYLINDER



- Technical data**
- Force: 20tons
 - Stroke: 8 mm
 - Dimensions: Ø100x60 mm
 - Pressure: max. 700 Bar
 - Hole: Ø33 mm
 - Adapter: Ø20 mm
 - Connection: 3/8" -18 NPT
 - Material: steel



GO CODE **1020**
with 2 pcs. 3 Kg

G + UPGRADE OPTION + HYDRAULIC PUMP - 700BAR HAND OPERATED



- Technical data**
- Maximum working pressure: 700 bar
 - Speed/stroke: single
 - Oil tank volume: 700 cm³
 - Oil volume per stroke: 500 cm³
 - Oil displacement per stroke: 1.8 cm³
 - Max effort on the handle to 700 bar:46 kg
 - Piston stroke: 24 mm
 - Piston: Ø10 mm
 - Conductive thermoplastic hose Ø9.7 mm
 - Connection: 3/8" NPT
 - Hose length: 1.8 mt

- Single-action manual pump, for operating hydraulic cylinders (max 700bar).
- The pump has particularly compact dimensions and an ergonomic design.
- Equipped with a drain valve that allows a controlled pressure reduction in total safety (depressurization).

SCREW CONNECTION
GO CODE **1030**
with 1 pcs. 4,7 Kg



QUICK CONNECTION
GO CODE **1030Q**
with 1 pcs. 4,7 Kg

G INJECTOR SET FOR FORD 2.0 ECOBLUE TDCI

FORD



- Set of special tools to remove FORD 2.0 ECOBLUE TDCI injectors (from 2016).
- Solution designed to remove highly blocked injectors in a professional, safe and fast way:

- 1 Complete extraction of the injector (no dismantled)
- 2 Broken injector extraction

- In the case that the injector breaks during the extraction, it is possible to use the tools.

APPLICATION	ENGINE	MODEL	CODE
Ford	Galaxy		
	S-Max		
	Mondeo		
	Focus	2.0 EcoBlue TDCI (from 2016)	YLF6 (77Kw), YLF6 (77Kw), YMF6 (96Kw), YMF6 (96Kw), YNF6 (125Kw), YNF6 (125Kw), YLR6 (77 Kw), YMR6 (96 Kw), YNR6 (125 Kw)
	C-Max		
	Transit		
	Transit Custom		
Tourneo Custom			



GO CODE **434**
with 17 pcs. 6,5 Kg

G CLEANING INJECTOR SEAT SET

- Kit to be used for removing the combustion residues that remain in the injectors seat **UNIVERSAL** without any damages.
- For cleaning and maintaining the injector shaft.

+ **INCLUDED**
Lubricating grease to be used with threaded bars, nuts etc...



1 Pipe cleaners for cleaning the headquarters of injector sprayer.

2 Sealing plugs for the injector housing.

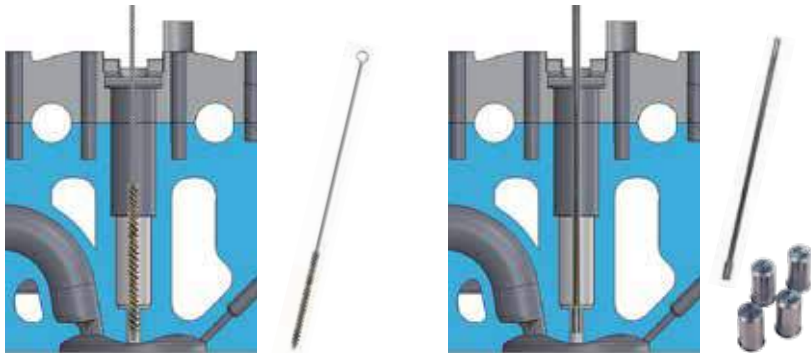

COMPONENTS	
4 x	sealing plugs Ø7 mm
2 x	brass brushes for cleaning the injector nozzle housing
10 x	cotton pad set

2 x	brush for cleaning the sealing seat
4 x	nylon brushes for cleaning the injector seat - Ø18-19-21-24 mm
4 x	brass brushes for cleaning the injector seat - Ø18-19-21-24 mm

1 x	flexible extension
4 x	milling cutters for sealing seatmilling
1 x	brush with brass fibers

3 Clening brush for seal seat

4 Special cleaning brushes for injector seat.

5 Cutters for cleaning the sealing seat.

6 Final finishing with cotton pad.

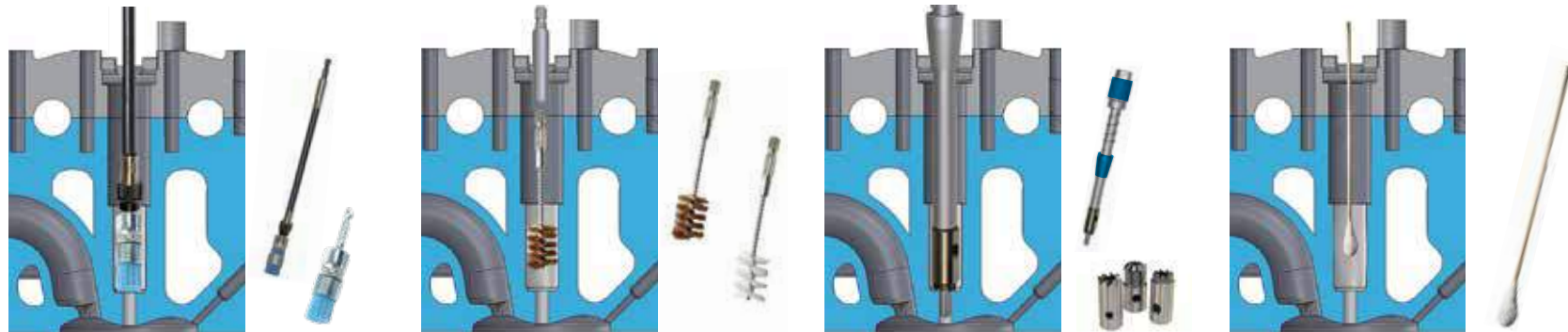

GO CODE **415**
with 26 pcs. 4 Kg

G GLOW PLUG REMOVAL KIT FOR FCA GROUP 1.3 MJ



FCA	OPEL	FORD	SUZUKI
	M8X1	M9X1	1.3 MJ

- Professional kit employed to extract stuck glow plugs, specifically for FCA group 1.3 Multijet.



COMPONENTS			
1 x	support plate L=284mm	1 x	male M8x1
1 x	centering guide L=120mm	1 x	male M9x1
1 x	extraction spindle M12	1 x	male 12-28 UNF
1 x	extraction nut M12-CH30mm	2 x	thread insert 12-28 UNF
2 x	screws M7	2 x	4 cutting edges drill Ø7-4,5mm
		1 x	4 cutting edges drill Ø8-4,5mm
		2 x	cylindrical tip Ø3,5mm
		2 x	guiding cylindrical hose Ø3,6mm
		1 x	extraction socket Ø4mm

APPLICATION	
BRAND	ENGINE
Alfa Romeo	1.3 JTD
Fiat	1.3 Multijet
Lancia	1.3 MJTD
Ford	1.3 TDCI

+ **PLUS**
New application for M9 glow plugs

Opel	1.3 CDTI
Suzuki	1.3 DDIS



GO CODE **489**
with 16 pcs. 4 Kg

G GLOW PLUG PULLER SET M8-M9-M10

M8	M9
UNIVERSAL	M10



- Since modern glow plugs are increasingly fragile and narrow, a glow plug that has been burnt out for a long time often gets stuck in its seat. Even if you try to unscrew it, it will not come out due to encrustation along its body and also because of deformation which occurred over time in the final part.
- This system quickly and directly grips the hex body of all types of M8-M9-M10 glow plugs. Features the innovative fast lock system that ensures maximum quickness.
- Does not damage the cylinder head and guarantees a job done to professional standard.
- Removal through the strokes of the slide hammer provided.

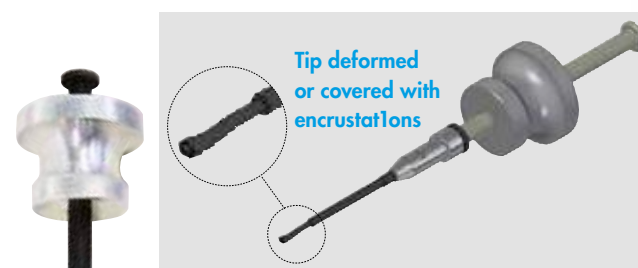

COMPONENTS	
1 x	glow plug extractor M8
1 x	glow plug extractor M9
1 x	glow plug extractor M10

GO CODE **453**
with 9 pcs. 2,5 Kg
§ PATENTED

G KIT ESTRAZIONE PUNTA CANDELETTE ROTTE

UNIVERSAL



- Set of tools for the extraction of the electrode terminal part of the glow plugs (M8, M9, M10) in the event of breakage or sticking inside the seat port.

- 1 Extraction with slide hammer
- 2 Extraction with threaded extractor

Solution 1
Pulling out with slide hammer



Solution 2
Pulling out with bearing threaded extractor

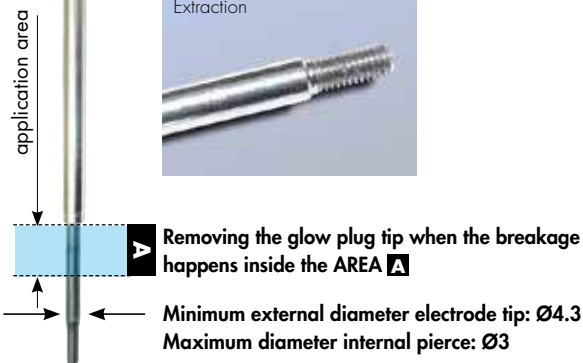
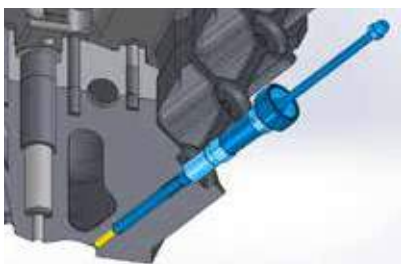

PLUS
Developed and reinforced for glow plug with ceramic bulb

COMPONENTS	
3 x	Tip Ø2,5 - 3,2 mm
3 x	Male (M3 - M4)
3 x	Threaded bars for slide hammer extraction (M3 - M4)
3 x	Threaded bars for spindle extraction (M3 - M4)
1 x	Socket with bearing for spindle extraction
4 x	Centering items (M8 - M9 - M10)
2 x	Nuts (M5 - M6)
1 x	Slide hammer



GO CODE **451**
with 20 pcs. Kg 2,5 Kg
\$ **PATENTED**

G UNIVERSAL GLOW PLUG REMOVAL SET

UNIVERSAL

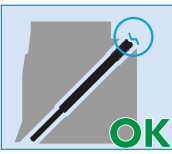

- The pre-heating glow plug used in diesel engines can often get stuck inside the engine head due to residues caused by the combustion process. In these cases, the glow plug will break when you try to remove it; consequently, you will have to disassemble the head in order to remove it. This job need in long intervention time and high costs.

- Govoni specializes in the extraction of broken or stuck glow plugs and allows you to carry out rapid and efficient extraction steps by using its highly professional equipment.



GO CODE **470**
with 29 pcs. Kg 5,3 Kg

APPLICATION	
SIZE	MODEL
M8x1	Mercedes, Smart, VW, Fiat, Opel, Ford ecc.
M9x1	Opel, Fiat, Alfa, Lancia (es. 1.3-2.3-3.0 JTD) ecc.
M10x1	VW, Audi, Mercedes, BMW, Opel, PSA, Renault, Ford, Suzuki ecc.
M10x1,25	VW, Audi, Toyota, Suzuki, Opel, Isuzu, Mercedes ecc.



G BASIC SET, FOR COMMON WORK



Uso de los componentes

- 3 x Controlled breakage and drilling out of the middle electrode (3 x sockets Ø2,5; Ø3,5; Ø4 / 2 x milling cutters Ø2,7; Ø3,6)
- 1 x pull rod with slide hammer (1,5 Kg) for knocking out the glow plug
- 1 x bar magnet for picking up fragments, chips, small parts

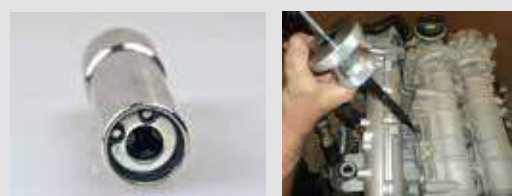

GO CODE **471**
with 12 pcs. Kg 5,2 Kg

G MODULE M8 - GLOW PLUG REMOVAL

M8



Components

- 1 x special long milling cutter (Ø4.5) and steel milling cutter (Ø7-4.5 mm) with 4 TiN-coated and self-centering cutting edges
- 1 x thread insert 12-28 UNF
- 1 x threaded male to create the thread to remove the glow plug 12-28 UNF
- 1 x threaded male to restore the M8x1 glow plugs thread



GO CODE **472**
with 5 pcs. Kg 0,5 Kg

G MODULE M9 - GLOW PLUG REMOVAL

M9



Components

- 1 x special long milling cutter (Ø4.5) and 1 x steel milling cutter (Ø8-4.5 mm) with 4 TiN-coated and self-centering cutting edges
- 1 x thread insert 12-28 UNF
- 1 x threaded male to create the thread to remove the glow plug 12-28 UNF
- 1 x threaded male to restore the M9x1 glow plugs thread



GO CODE **473**
with 5 pcs. Kg 0,5 Kg

G MODULE M10 - GLOW PLUG REMOVAL

M10



Components

- 1 x special long milling cutter (Ø5.5) and 2 x steel milling cutters (Ø8.9-5.5 mm) with 4 TiN-coated and self-centering cutting edges
 - 1 x thread insert 12-28 UNF
 - 1 x threaded male to create the thread to remove the glow plug 12-28 UNF
 - 2 x threaded male to restore the glow plugs thread (M10x1; M10x1.25)
- Dimension A ≥ 14 mm + ≥ 20 mm



GO CODE **474**
with 7 pcs. Kg 0,6 Kg



CIRCLIP PLIERS SET

NEW



Measure the outer diameter of the serration. Choose the suitable half shell size which sufficiently encloses the serration.
Note: Size information can be found on the underside of the half shells

Q.TY	COMPONENTS	TECHNICAL DATA
1 x	Circlip pliers	
2 x	Half shell pair	Ø23.8 mm
2 x	Half shell pair	Ø24.6 mm
2 x	Half shell pair	Ø26.9 mm
2 x	Half shell pair	Ø28.5 mm

- Locking pliers supplied with 4 sets of interchangeable clamps for tightening the snap ring on the transmission shaft to reinstall the seal (bowl) on the transmission when using the SNR OBK (Outer Boot Kit) and OJK (Outer Joint Kit) types.
- The rush compressed by the conical shell will be released when hitting the bowl. This pliers ensure a mounting without risk of damage of the rush (clips), or the teeth when inserting the bowl on the transmission shaft.

Easier attachment and sliding of the drive shaft joint onto the drive shaft by a special half shell shaping.



GO CODE **829**
 with 9 pcs. 0,8 Kg
 PATENTED



EXTRACTION SET DRIVE SHAFTS AND CV JOINTS FOR HUBS

UNIVERSAL VEHICLES



- For pressing out seized and bonded drive shafts and also, with the optional Govoni slide hammer **GO520**, for removing the wheel hub.
- Considerable time savings - no damage to the thread - wheel bearing is not damaged - Optimised hole pitch for maximum coverage of models within the market.
- Suitable for 2, 3, 4, 5 and 6-hole bolt pitch on hubs with stud bolts and wheel bolts
- For use on all vehicles ranging from passenger cars to transporters, and particularly for extremely firmly anchored drive shafts on VW Group, Mazda, Ford, BMW, Renault and Peugeot.
- When extreme force is required, can also be used with **GO1016**.



COMPONENTS

1 x	extractor with mounting thread 1-1/2"-16G
1 x	reducing adapter ring for mechanical spindle, 1-1/2"-16G x M22x2
1 x	mechanical spindle, M22x2
1 x	pulling flange, 96-142 mm for M12/M14 bolts
5 x	conical washers
6 x	conical spacers



Technical data

- Slotted mounting hole: M12 and M14
- Working range:
M12: Ø96-138 mm
M14: Ø98-136 mm



GO CODE **010**
 with 16 pcs. 4,8 Kg



17T HYDRAULIC CYLINDER

STEEL



Technical data

- Dimensions: Ø90x155 mm
- Pressure: max. 700 Bar
- Hole: Ø20 mm
- Connection: 3/8" -18 NPT
- Outside connection thread: 2" 3/4-16 UN



17T HYDRAULIC CYLINDER

ALUMINIUM



Technical data

- Dimensions: Ø90x155 mm
- Pressure: max. 700 Bar
- Connection: 3/8" -18 NPT
- Outside connection thread: 2" 3/4-16 UN
- Adaptors: M10/M12/M14/M16/M18



HYDRAULIC PUMP - 700BAR HAND OPERATED

- Single-action manual pump, for operating hydraulic cylinders (max 700bar).
- The pump has particularly compact dimensions and an ergonomic design.
- Equipped with a drain valve that allows a controlled pressure reduction in total safety (depressurization).



Esempio di utilizzo



Technical data

- Maximum working pressure: 700 bar
- Speed/stroke: single
- Oil tank volume: 700 cm3
- Oil volume per stroke: 500 cm3
- Oil displacement per stroke: 1.8 cm3
- Max effort on the handle to 700 bar:46 kg
- Piston stroke: 24 mm
- Piston: Ø10 mm
- Conductive thermoplastic hose Ø9.7 mm
- Connection: 3/8" NPT
- Hose length: 1.8 mt

GO CODE **1017**
 with 1 pcs. 4 Kg

GO CODE **1017Q**
 with 1 pcs. 4 Kg

GO CODE **1061**
 with 7 pcs. 2,2 Kg
 PATENTED

GO CODE **1061Q**
 with 7 pcs. 2,2 Kg
 PATENTED

GO CODE **1030**
 with 1 pcs. 4,7 Kg

GO CODE **1030Q**
 with 1 pcs. 4,7 Kg

G EXTRACTION SET DRIVE SHAFTS AND CV JOINTS FOR HUBS

COMMERCIAL VEHICLES



- Aimed to remove locked and tighten drive shafts, and by using the Govoni slide hammer (GO520 or GO530), also wheel hubs.
- Considerable time savings - no damage to the thread - wheel bearing is not damaged.
- Optimized hole pitch for maximum coverage of models within the market (suitable for 2, 3, 4, 5 and 6-hole bolt pitch on hubs mounted on passenger cars and commercial vehicles).
- When an extreme forced is required, max till 17 ton, use Govoni Mechadraulic-Spindle GO1016 (optional) or hydraulic cylinder GO1061 (optional).

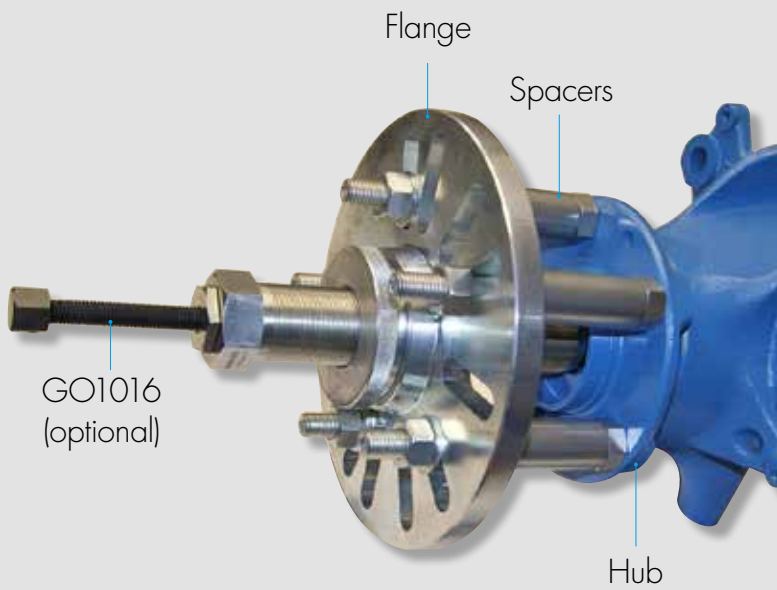

Technical data

- For nut and bolt systems: M12/M14/M16/M18
- Working range: Ø115-186mm
- Slotted hole connection: Ø14 mm
- Tension bolt length: 80 mm

GO CODE **060**
with 43 pcs. 12,7 Kg

G + UPGRADE OPTION + 16T MECHADRAULIC SPINDLE ADAPTOR SET

Universal application for different types of extraction kits.



- Due to the mechanical properties, shape and size, the Govoni Mechadraulic-Spindle is optimally suited for use in the automotive sector: removal and installation of wheel hubs, drive shafts, supporting joints, tie rod heads, pitman arms, silent bearings etc.
- The 1-1/2 inch x 16 tpi receiving thread is one of the most commonly used special tool threads.

Technical data

- Force: 16 ton
- Dimensions: Ø38x225x345 mm
- Driving torque: 38 Nm
- Receiving thread: 1-1/2 inch x 16 tpi
- Stroke: 20 mm

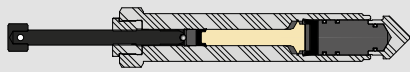

GO CODE **1016**
with 7 pcs. 2,2 Kg

G + UPGRADE OPTION + SUPPLEMENTAL SET OF SPACERS



- Useful addition to Govoni's GO010 and GO012 kit for the removal of CV joints.
- This kit ensures a strong flange connection with the hub and is also suitable for systems with wheel nuts and/or bolts. The user is not bound to the diameter of the hub edge since the hub's flange is placed 80mm or 90mm in front of the hub.



COMPONENTS	
5 x	M12x1,25 spacers kit for hub flange
5 x	M12x1,5 spacers kit for hub flange
5 x	M14x1,5 spacers kit for hub flange



GO CODE **070**
with 25 pcs. 5,2 Kg

G BALL JOINT BI-HEX SOCKET 32 MM

MERCEDES



A 002 990 68 54

- Technical data**
- Size: Ø42 mm
 - Height: 40 mm
 - Drive 1: CH32
 - Drive 2: 1/2"
 - Drive 3: CH27

€ 85,-
€ 78,-*
GO CODE **352**
with 1 pcs. 0,2 Kg

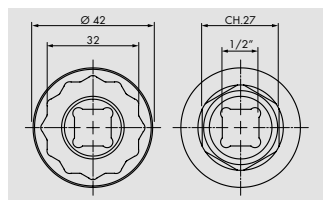

G BALL JOINT BI-HEX SOCKET 24 MM

MERCEDES



A 005 990 24 50

- Technical data**
- Size: Ø42 mm
 - Height: 40 mm
 - Drive 1: CH24
 - Drive 2: 1/2"
 - Drive 3: CH27

€ 85,-
€ 78,-*
GO CODE **353**
with 1 pcs. 0,2 Kg

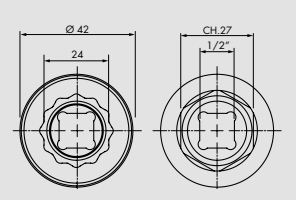

G BALL JOINT BI-HEX SOCKET 32 MM

NEW

FORD



2 216 529

- Technical data**
- Size: Ø48 mm
 - Height: 50 mm
 - Drive 1: CH32
 - Drive 2: 1/2"
 - Drive 3: CH30

APPLICATION	
BRAND	MODELS
Ford	C-Max Energi 2014-2018, C-Max 2018-2019, focus from 2018, Kuga 2017-, Mustang 2015-, Connect MK2 Turneo connect 2017-

€ 60,-
€ 59,-*
GO CODE **354**
with 1 pcs. 0,2 Kg

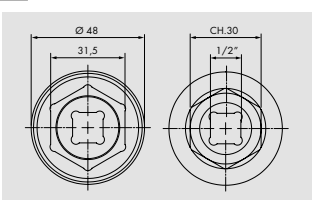

G HUB EXTRACTOR SET



- Set required to remove quickly and safely hubs and compact hubs and bearings without locking ring **1**.
- The tool can be easily assembled in different configurations according to the characteristics of the hub or hub and bearing to be removed.
- The set includes 3 different pairs of support feet, a sturdy bar support and a spindle with bearing all components capable of guaranteeing a high thrust force.
- The set can be an excellent addition to the **GO015** wheel bearing extraction set.

UNIVERSAL



+ **INCLUDED**
Lubricating grease to be used with threaded bars, nuts etc...

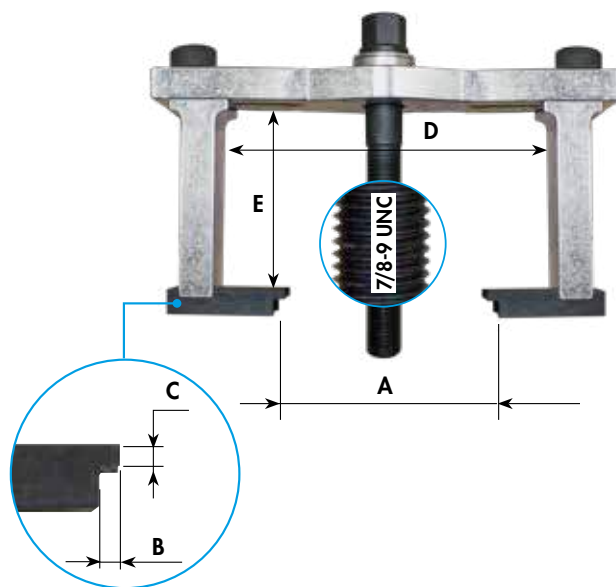
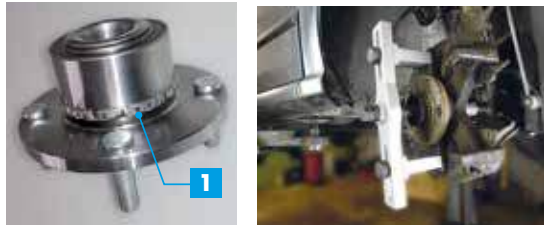

APPLICATION						
Universally applicable on front and rear wheel hubs, and on compact bearings without locking ring						
COMPONENTS		A (mm)	B (mm)	C (mm)	D (mm)	E (mm)
STRUCTURE		-	-	-	min: 12 max: 22	min: 7 max: 11
FOOT N.1		13,5	15	5,2	-	-
FOOT N.2		13,5	15	2,1	-	-
FOOT N.3		13,5	14,5	5,2	-	-



GO CODE **046**
with 21 pcs. 9,5 Kg

G WHEEL BEARING TOOL SET

UNIVERSALE

+ **INCLUDED**
Lubricating grease to be used with threaded bars, nuts etc...

+ **PLUS**
Centraggio ed allineamento dei componenti preciso e sicuro



- Complete set for mounting and dismounting wheel bearing and for assembling hubs.
- The large number of pressure bushes and centering washers allows the product to cover a wide range of models and applications.
- **1** Bearing installation = pressure on the bearing outside ring.
- **2** Hub installation = pressure on the bearing inner ring.
- Direct application on the vehicle.

1 Bearing installation



2 Hub installation

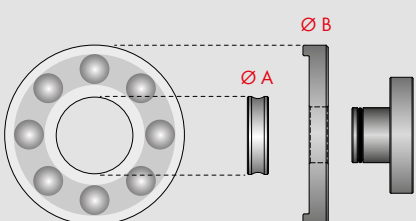

Ø B	bearing pressure ring	ø 60, 62, 64, 66, 68, 70, 72, 74, 76, 78, 80, 82, 84, 85 mm
Ø A	bearing centring ring	ø 30, 34, 35, 37, 38, 39, 40, 41, 42, 43, 45, 48 mm



GO CODE **015**
with 39 pcs. 13,2 Kg

G WHEEL BEARING SET XXL BASIC

FROM Ø85.5MM TO Ø99 MM

- Set for the disassembly and assembly of Ø 85 mm wheel bearings and for the installation of the wheel hub directly on the vehicle or with the help of a workshop press.
- It is an addition to the **GO015** wheel bearing kit and is designed to house the components of both sets. (also available as a complete set **GO018** incl. chuck).

Fig.1 Bearing installation = pressure on the bearing outer ring

Fig.2 Wheel hub installation = pressure on the bearing inner ring.

+ **UNIVERSAL**
to cover a wide RANGE OF VEHICLES!

+ **PLUS**
49 possible combinations!



3-PART PRESSURE ELEMENT
THIS ALLOWS AN EXACT FIT TO THE INNER BEARING - Ø A AND OUTER - Ø B!

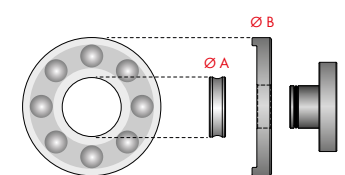

COMPONENTS	
7 x	bearing pressure ring Ø85.5/87.5/89.5/91.5/95.5/97.5/99 mm
7 x	bearing centring ring Ø44.5/48.5/49.5/50.5/53.5/54.5/57.5 mm
1 x	pressure ring for press Ø43 mm
2 x	support Ø95/Ø100 mm
1 x	centring device for supports Ø95/Ø100
1 x	pressure plate for press
1 x	guide for bearing
1 x	M20x1.5 screw L=300
1 x	nut + OR + bearing
1 x	M20x1.5 L=50 nut

APPLICATION
Ideal for wheel hubs and bearings on large cars.
It can be used on silentblocks / bushings / sleeves etc.

GO CODE **019**
with 23 pcs. 9,2 Kg

G DOUBLE CONE BEARING REMOVAL KIT

NEW

UNIVERSAL

Slide hammer technical data

- Weight: 3Kg
- Total length: 580mm
- Connection - Thread: M18x1.5

- For the quick removal of wheel hubs and bolted wheel bearings. Simple and efficient method to remove front wheel hubs quickly and without too much effort in terms of assembly.

APPLICATION
Injectors, hubs, support joints, bodywork works

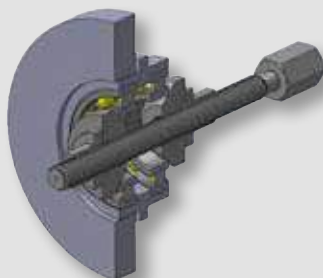
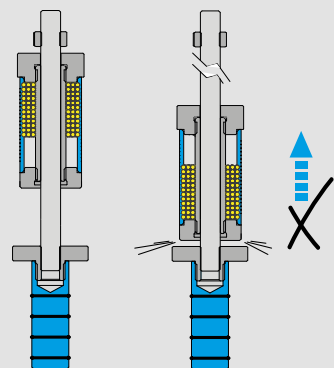

~~€ 549,-*~~
€ 478,-*
GO CODE **439**
with 14 pcs. 10 Kg



The new slide hammer version is filled with a steel shot. This prevents the weight from bouncing back against the abutment. The impact intensity is thus increased because the full impact force is transmitted to the component to be machined.

Removing the wheel bearings

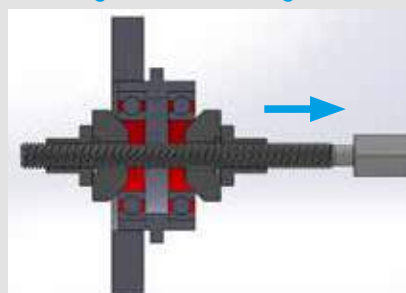

Removing the wheel hub bearings

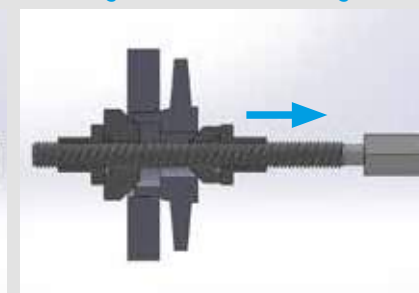

G EXTRACTION SET FOR BEARING INNER NUTS, FOR Ø 35 - Ø 55 MM

UNIVERSAL



- This set allows to extract easily and quickly the inner ring of the bearings without damages.
- Usually extracting the hubs, the rings remain in their seats and without a special tool is not possible to remove them.

CLAMPING SLEEVE SIZE

323016014 323016004 323016003 323016005



Ø35-40 mm

Ø40-45 mm

Ø45-51 mm

Ø50-55 mm

GO CODE **021**
with 11 pcs. 5 Kg

G MECHANICAL COIL SPRING COMPRESSOR



- Suitable as a removal aid for MacPherson spring struts, for rear axle springs and for broken springs.
- Enables the removal of the spring strut from the clamping bore in the axle casing without additional removal of various axle components or without lowering the sub-frame (support frame).



PLUS
Non-slip as each spindle has a right- and left-hand thread.
Saves considerable time and money, as there is no need for a complicated wheel alignment.
Clamping range: short spindle 90 - 180 mm, long spindle 110 - 315 mm

GO CODE **340**
with 9 pcs. 4,3 Kg

G WHEEL ALIGNMENT CAMBER DEVICE

UNIVERSAL

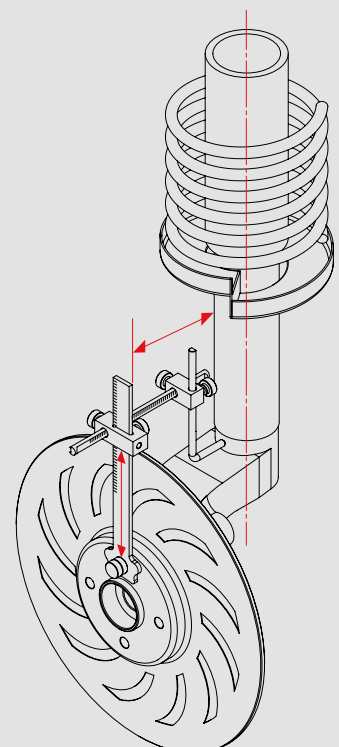

- Special diagnostic tool set, necessary for strain detection on hubs, shock absorbers and rear axle; with this tool the operator is able to find the non-conforming parts that have to be replaced because of collisions or potholes on the road.
- Allows the user to identify what is compromising the camber measure between the hub and shock absorber.



PLUS
Use directly on the hub wheel

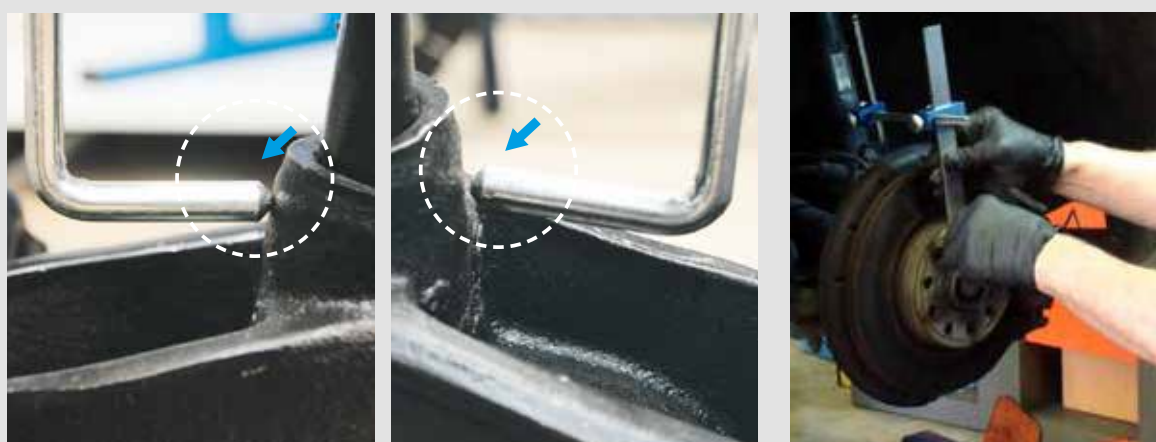

GO CODE **350**
with 18 pcs. 1,3 Kg

§ PATENTED



TRANSMISSION JACK

MADE IN ITALY

0.3 TON

1 TON



0.6 TON

1.5 TON

- This jack are designed and manufactured for the use in pit or under two or four post lift, to remove and install engine, gearboxes and heavy parts of the veichles.
- Solid strong structure, on four wheels, guarantee stability in all the correct operating position.
- All the models are supplied with the suitable plates.
- Equipped with wheels.

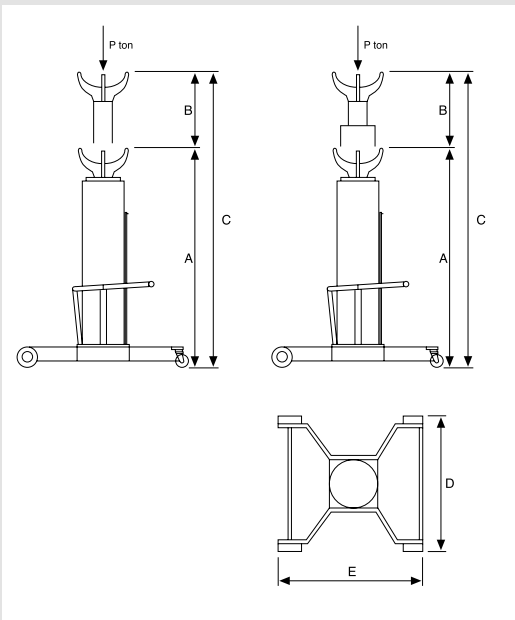

CODE	CAPACITY	A (mm)	B (mm)	C (mm)	D (mm)	E (mm)	N. PISTON	Ø PISTON (mm)	WEIGHT	
1 PISTON	GO1450	0.6 Ton	1150	850	2000	370	500	1	35	35 Kg
	GO1451	0.3 Ton	1150	850	2000	350	500	1	25	28 Kg
	GO1452	1 Ton	1200	850	2050	490	580	1	40	50 Kg
	GO1453	1.5 Ton	1200	850	2050	490	580	1	45	55 Kg



SUPPORT FOR DETACHING AND REFITTING GEARBOXES AND AUTOMATIC TRANSMISSIONS

COMPATIBLE WITH MOST COMMON GEARBOX LIFTERS

- Universally applicable for gearboxes, automatic transmissions and DSGs as well as differential gears etc.
- The front and rear supports and arms, which can be adjusted in distance and tilt angle, provide a secure grip during application and removal.
- The support is applied to the gearbox which can be tilted forwards/backwards and right/left, always ensuring a secure grip.
- The tool include adapter for hydraulic gearbox lifter piston rod Ø30mm.



Even the front bar can be inclined of 5° in both directions, loosen the lower hexagonal screw on the main bar on the central part

COMPONENTS

1 x	support with arms for attachment to the gearbox, fixing strap included
1 x	adapter for hydraulic gearbox lifter piston rod Ø 30mm

Note

if the piston diameter is Ø 25 mm, the adaptor (Art.N. 391 018 002) is available on request

To be used together with a hydraulic gearbox lifter, it is particularly practical and quick for detaching and refitting gearboxes, in particular those for automatic transmissions

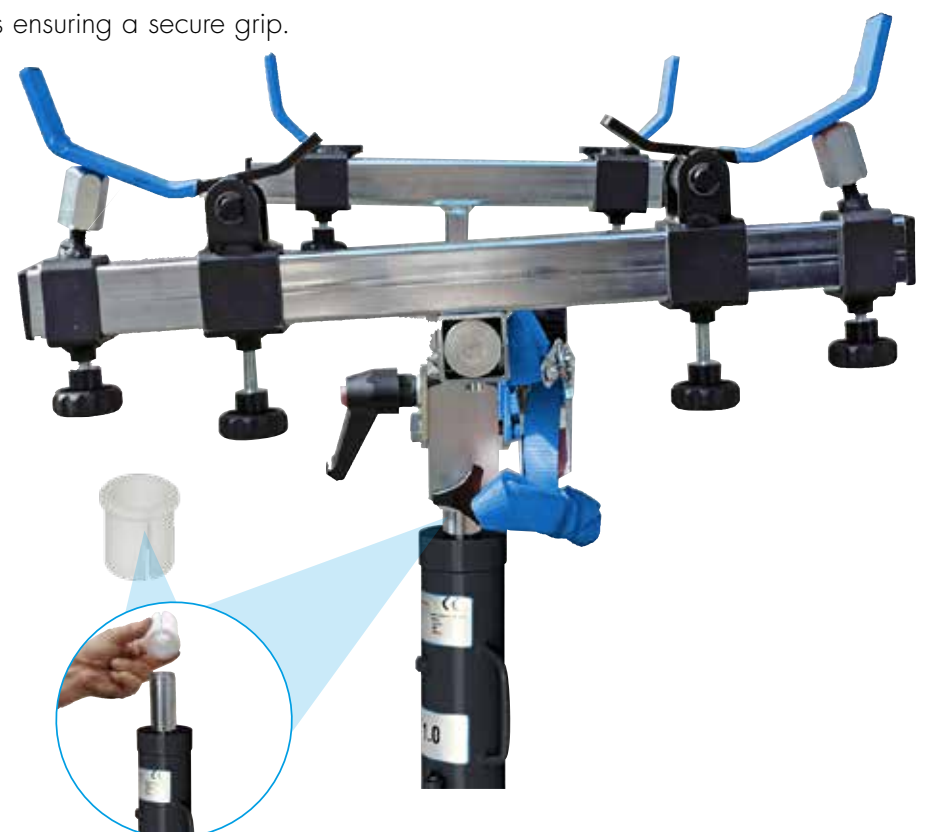

UPGRADE OPTION SET OF ADAPTERS FOR PIT LIFTS

- Allows you to use Govoni's items in combination with pit lifts of other manufacturers. The lift's stem is not damaged thanks to the plastic finish of the adapters.



On request

GO1450,
GO1451,
GO1452,
GO1453

Technical data

- Weight: 12 kg
- Max. load bearing capacity: 150 kg
- Length/width: 490 mm/460 mm
- Assembly: Ø 40 mm
- Forwards/backwards tilt: ±35°
- Left/right tilt: ±5°

GO CODE 102
with 3 pcs. 0,2 Kg



GO CODE 925
with 2 pcs. 12 Kg
PATENT PENDING

G STUB AXLE PROP

CARS AND COMMERCIAL VEHICLES | UNIVERSAL

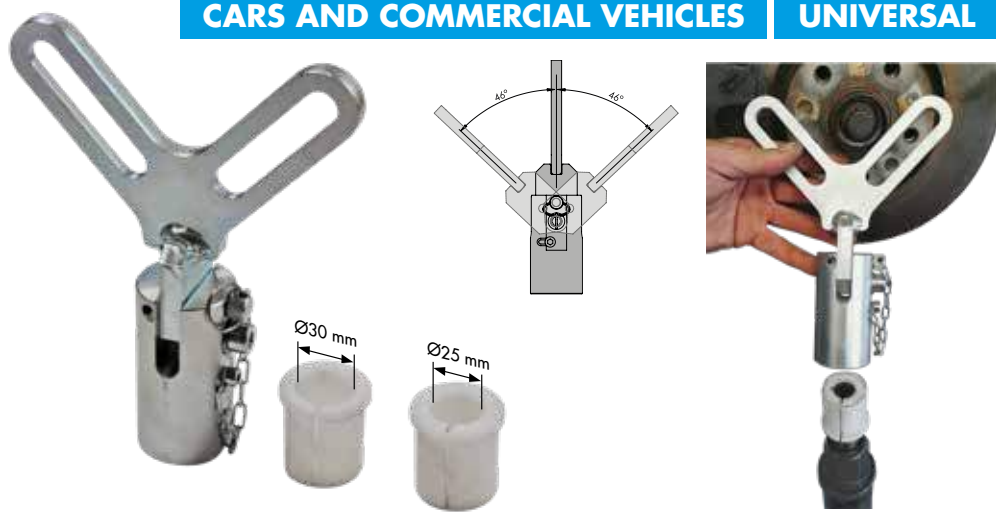

- The universal wheel hub holder is V-shaped and therefore can be fixed on the bolts of all hubs, designed to be coupled with the bolts that secure the wheels.
- The kit include the adapters for hydraulic pit jacks piston rod Ø 25 and 30mm.
- Compatible with approximately 95% of hydraulic pit jacks, thanks to the adapters for various piston rod diameters supplied with the kit.

APPLICATION

Disassembly and assembly of the upright and the support joint or trapezoid of the suspension cross arm.

Load bearing test according to manufacturer specifications to highlight noise.

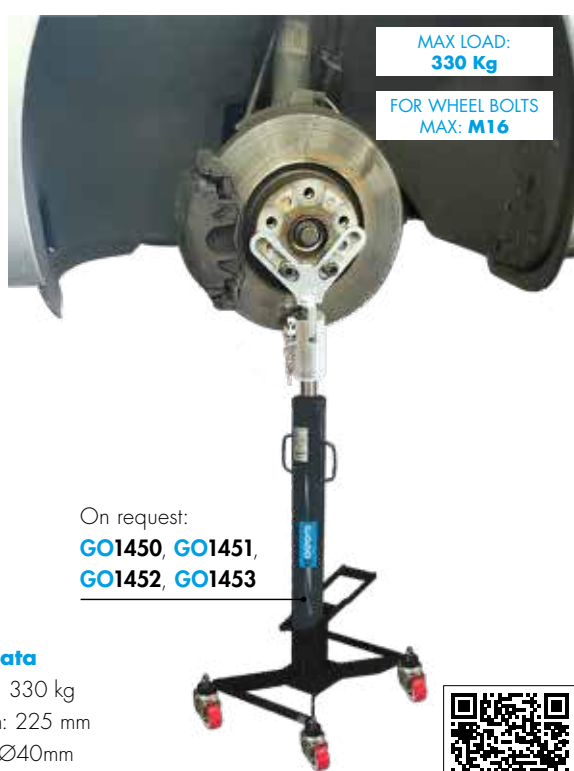

On request:
**GO1450, GO1451,
GO1452, GO1453**

Technical data

- Max. load: 330 kg
- Total length: 225 mm
- Assembly: Ø40mm
- Tilt angle: ± 46 ° (forwards + backwards)
- For wheel bolts: max. M16

GO CODE **366**
with 3 pcs. 1,5 Kg



G MACPHERSON STRUT SUPPORT FOR JACK **NEW**

+ **PLUS**
THE ADAPTER PLATE ALLOWS FOR SHOCK ABSORBERS WITH REDUCED SHAFT DIMENSIONS TO BE INSTALLED, THUS EXTENDING THE FIELD OF APPLICATION



COMPONENTS

1 x	MacPherson strut support
1 x	reduction for MacPherson strut support
1 x	adapter plate for pit lifter 60 mm
1 x	Ø 25 mm adapter
1 x	Ø 30 mm adapter

- The spring strut support is used in combination with a standard transmission jack.
- It is used to prevent the strut from dropping as soon as it has been removed from the control arm.
- The set includes two reducer sleeves for piston rods Ø 25 and 30 mm.
- The safety bracket prevents the mounting support from slipping out.

The safety bracket prevents the mounting support from slipping out.



GO CODE **316**
with 6 pcs. 3 Kg

G DEVICE FOR SWINGING ARMS AND SHOCK ABSORBERS REMOVAL - DOUBLE ARM SYS.

**MAX TORQUE
50Nm**



Technical data

- Length: 1000 mm
- Height: 120 mm
- Width: 450 mm
- Ultra-fast operation: use of impact gun.

GO CODE **370**
with 1 pcs. 13,2 Kg

§ **PATENTED**

REMOVAL OF BOTH OSCILLATING ARMS

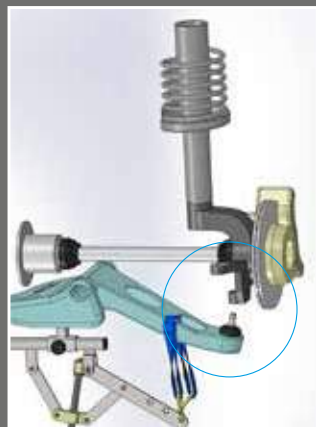

REMOVAL OF SHOCK ABSORBER

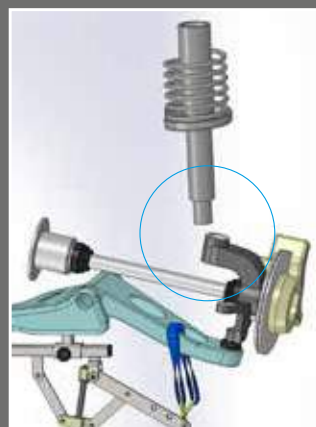

- Creates maximum clearance for repair work without the need for additional loosening or removal of various axle components.
- Overcomes even high levels of counter tension on the steering arm with minimal force and prevents damage to the dust boot on the supporting joint.
- Removal through belt which guarantees utmost safety and keeps arms intact.
- Sliding support feet to fit any undercarriage.



YouTube



G

ENGINE AND GEARBOX SUPPORT - ARMS ROTATION



MAX 240KG UNIVERSAL



- This special device allows to support the engine when the side engine bracket is removed, e.g. during maintenance work on thrust bearings, timing belts, water pumps or tensioner rollers.
- After loosening the engine mount, the engine support safely holds the vehicle engine in the engine compartment (time savings and higher safety at work).

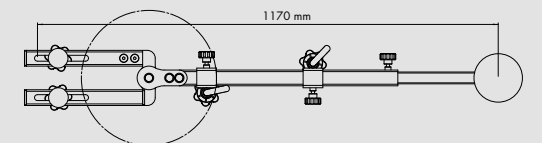
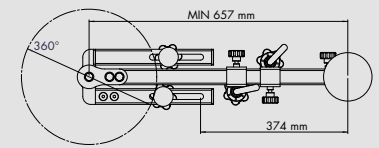
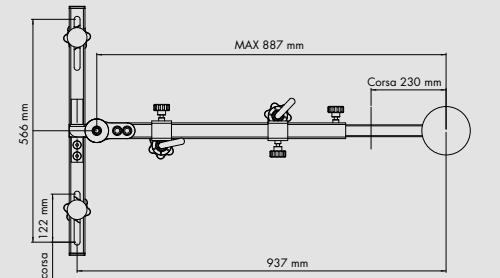

COMPONENTS	DIMENSIONS
2 x rotating arms	Rotation 360°
1 x main telescopic bar	min 657 - max 887 mm
1 x transmission jack connection	Ø 40 mm



GO CODE **646**
with 1 pcs. 12 Kg
§ PATENTED

G

UPPER ENGINE SUPPORT

UNIVERSAL
MAX 500KG

Versatile lateral bars and support feet, adjustable in height, position, inclination and angle, granting the tool to be applied on numerous vehicles.

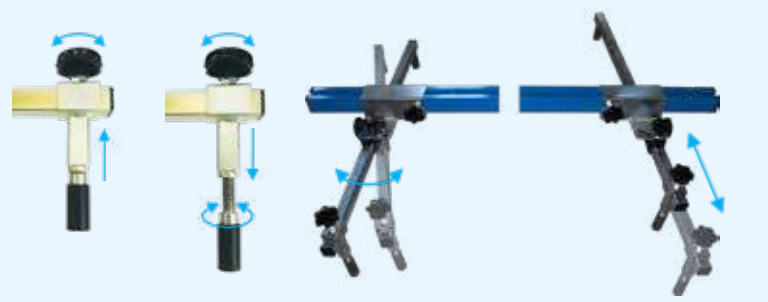

- Upper engine support designed to ease the engine being lifted while is positioned on the vehicle front axle.
- The supplied chain allows fixing the engine, granting security and a firmly hold.
- This tool is ideal when dismantling the undercarriage is rather laborious, especially when the operator has to use a lower support (transmission jack...).
- The tool is equipped with a 4-wheel support system, adjustable in height, manufactured in scratch-resistant and slip-resistant material, assuring great stability and avoiding dangerous overturning.



GO CODE **650**
with 1 pcs. 18,7 kg

Q.TY	COMPONENTS
2 x	Traverse laterali scorrevoli e rotanti L=87 cm - Rotazione 32°
4 x	Piede di appoggio regolabili H - min 9 - max 21 cm
1 x	Barra filettata di sollevamento L=46 cm
1 x	Catena L=90 cm
1 x	Telaio traversa L=1,5 m



G **+** **UPGRADE OPTION** **+**
SUPPLEMENTARY
ADJUSTMENT FOOT SET

- It allows the application of the support on long bars or deep auxiliary frames in the engine compartment, as well as on a shock absorber head, located deep behind the partition bulkhead of the engine compartment/water dripper.



GO CODE **696**
with 6 pcs. 2,5 Kg

G BEARING REMOVAL AND MOUNTING PRESS SUPPORT

UNIVERSAL

- The tool set is made up of a supporting base and its accessories which allow the user to mount/dismount bearings into/from their housing.
- This tool's universal feature consists in being able to adapt to the irregular geometric shapes of hubs/king pins on which the operator must often intervene.

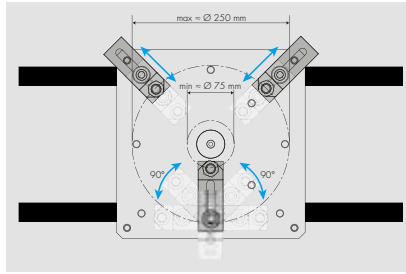

Universal system which allows the assembly and disassembly of hubs/bearings and silentblocks * (to be used with the code **GO140**) by operating under a press.

Technical data

- Dimensions: 300x300 mm
- Weight: 13 Kg
- Max. load-bearing capacity: 20 t
- Working range: min. 130 mm - max. 186 mm

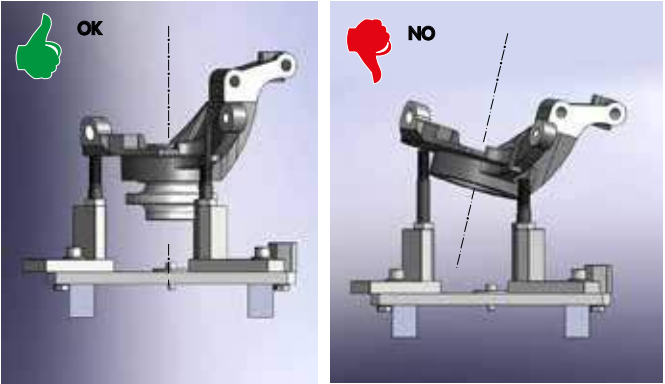

* Example of silent block extraction



G + UPGRADE OPTION + CENTERING ATTACHMENT SET FOR GO050



- Useful addition to the Würth press table support **GO050** and for support bolts ØM14.
- The centering attachments allow the fixing of the support bolts in a hole on the component.
- Delivery includes magnetic strip for neat storage directly at the workshop press.

GO CODE **052**
T with 14 pcs. kg 0,6 Kg

G + UPGRADE OPTION + MANDREL PRESS PINS SET



- Useful supplement for every workshop press up to 25 tons.
- With the help of the press mandrels, small components up to 29mm can be squeezed out safely.
- The press mandrel support can be attached directly and permanently to the piston of commercial workshop presses.

GO CODE **053**
T with 10 pcs. kg 5,2 Kg

follow us on YouTube



GO CODE **050**
T with 11 pcs. kg 13 Kg
\$ PATENTED

G SILENTBLOCK EXTRACTION/INTRODUCTION SET

UNIVERSAL

- Suitable for all passenger cars and commercial vehicles silentblocks.
- This tool can be used without disassembling steering arms.
- Extraction/introduction can be also performed through a combination of this set and the hydraulic cylinder or mehadraulic cylinder 12 T (upon request).



COMPONENTS

20 x	sleeves (internal diameters 34-72 mm/ external diameters 44-82 mm/H = 55 mm)
6 x	sleeve holder plates
2 x	centring bushes with pressure bearings
4 x	threaded bars (M10x1.5, M12 x 1.75, M14x2, M16x2)
8 x	pressure nuts (2xM10, 2xM12, 2xM14, 2xM16)
1 x	lubricating grease

APPLICATION

Silentblock
Wheel bearings
Sleeves
Bushings made from metal/plastic/brass etc

Modulate mounting bushing to remove silentblock up to l=100mm

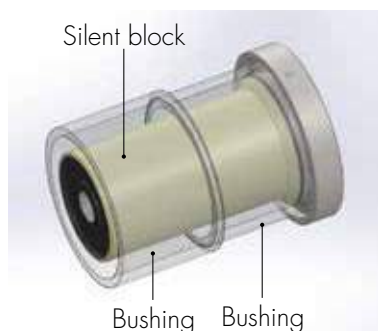

GO CODE **140**
T with 41 pcs. kg 9 Kg
\$ PATENTED

G SILENTBLOCK EXTRACTION/INTRODUCTION SET

OPEL
FIAT
FORD



- Kit suitable for silentblock rear axle, designed both for assembling and disassembling.
- Safety use, without damaging the arms.

APPLICATION

SILENTBLOCK	BRAND	MODEL
Ø45 mm	Fiat	Panda (4x4 - Cross - CNG)
Ø45 mm	Fiat	500
Ø45 mm	Ford	Ka
Ø54 mm	Ford	Ka
Ø54 mm	Opel	Adam

PLUS
Intervention directly on the vehicle!



Removing silentblocks of Fiat Panda (4x4, cross, CNG)



Removing silentblocks Fiat 500 / Ford Ka



GO CODE **130**
T with 10 pcs. kg 9 Kg

G 4-SIZE BALL JOINT SEPARATOR

UNIVERSAL

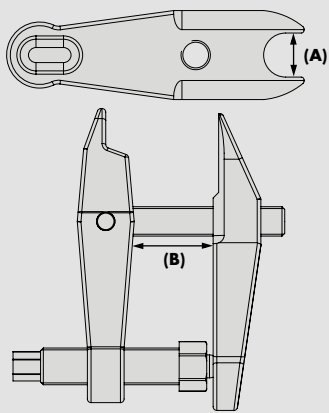

- Universal application for thrust heads and transverse rods, as well as for support joints. Especially suitable for new car models with multi-link aluminium suspensions where ball joints are often very big and very close together.
- Parallel plans functioning system.

FORK OPENING (A)	WORKING RANGE (B)
24 mm	25 - 90 mm
27 mm	
31 mm	
36 mm	

+ **PLUS**
Time saving set preventing damages on the components.

+ **INCLUDED**
Thrust spindle with trapezoidal thread, for impact wrench use.

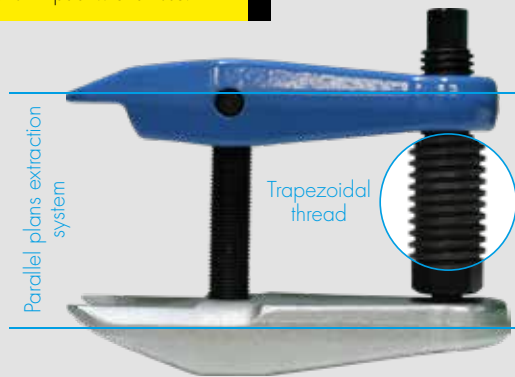

GO CODE **380**
with 6 pcs. 6 Kg

APPLICATION	
BRAND	MODEL
BMW	For cars, vans and small-sized commercial vehicles.
Mercedes	
Porsche	
VW / Audi	

G SHOCK ABSORBERS, SWIVELLING ARMS, STEERING BOX CLAMP SPREADER TOOL SET

UNIVERSAL



- Tool set allowing the enlargement of shock absorbers clamping bores, balljoints, steering box etc.
- Adjustable and adaptable to both single and double clamping bore, especially for VW-Group.

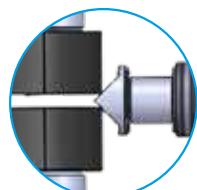

Example application on single clamping bore

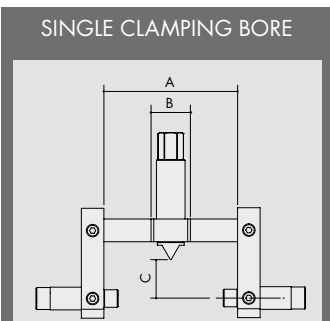

A	74,8 mm
B	22 mm
C	min. 11,5 mm - max 24,5 mm

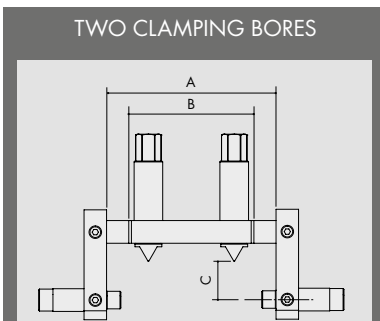

A	94,8 mm
B	70 mm
C	min. 11,5 mm - max 24,5 mm



COMPONENTS	
FIXING NUTS	
6 x	2xØ 8-10 mm 2xØ 10-12 mm 2xØ 9-11 mm
SPREADER CLAMPS	
7 x	2x5 mm nero 2x8 mm argento 1x11 mm 1x13 mm nichel 1x18 mm tutto nichelato

GO CODE **361**
with 20 pcs. 2,4 Kg

G CLAMP SPREADER SUPPLEMENTARY SET



- Additional set for **GO360**: 3 new wedge shapes and a new couple of locking bolt, allowing the operator to work on bigger and deeper joints (e.g. Peugeot, VW etc.).



COMPONENTS	
FIXING NUTS	
2 x	Ø9/Ø11
FIXING NUTS	
3 x	11 mm/13 mm/18 mm



GO CODE **362**
with 5 pcs. 0,2 Kg

G PLIERS FOR WHEEL BALANCING WEIGHT DETACHMENT

UNIVERSAL

- Ideal for attaching and detaching the weights applied to car rims, including adhesive ones, at 95%. The head, when tapping, prevents damage to the rim.
- Includes pinching device to fold the clip onto the impact weights.
- When removing the adhesive weights, the gripping jaws do not touch the aluminium edge, which avoids damage.
- Good handling, thanks to the automatic opening function.

+ **PLUS**
For almost all impact and adhesives weights!

Smontaggio del peso battente

Smontaggio peso adesivo

Montare il martello



pecial grip profile

Removable protective cap

Convenient clip folding function



GO CODE **075**
with 1 pcs. 0,54 Kg



G EXTRACTOR FOR STEERING SYSTEM

UNIVERSAL



Technical data

- Passengers cars and trucks:
Ø 43,2 mm - 20,25 mm



GO CODE **356**
with 1 pcs. 1 Kg

G UPPER BRACKET FOR SPRING COMPRESSOR MACHINE

UNIVERSAL



- The bracket is able to adapt to a vast number of applications since it is equipped with a rotating and universal plate with fixing holes and slots.
- The advantages come into play particularly:
 - ✓ With springs with a small number of coils, meaning that one more coil can always be tensioned automatically.
 - ✓ Dismantling and assembly operations are considerably simplified
- The rotatable and fixable mounting plate is provided with a universal hole division. In addition, the holder between the arms can easily be tilted. Suitable for Spring Compressor Machine **GO312/GO320/GO325/GO330**

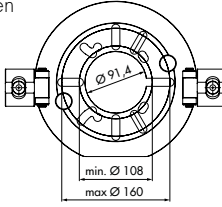

APPLICATION	
BRAND	MODEL
Nissan	Qashqai
Renault	Talisman, Megane, Master 3° Serie, Kajar, Koleos
Peugeot	208, 3008, 5008

Tesla	S
Bmw	X1, X2, X3, X4, X5, Serie 1, Serie 2
Ford	Transit
Mercedes	Classe A, B, C, E
Mini	Clubman, Countryman

GO CODE **338**
with 1 pcs. 5,5 Kg
PATENTED

G COIL SPRING CLAMP

UNIVERSAL



- Tool to secure coil spring into lower bracket for use with the Govoni range of suspension workstations.
- Designed to hold the coil spring still during initial compression and restrict twisting through the bracket.
- Added protection to prevent scratching the coil spring.

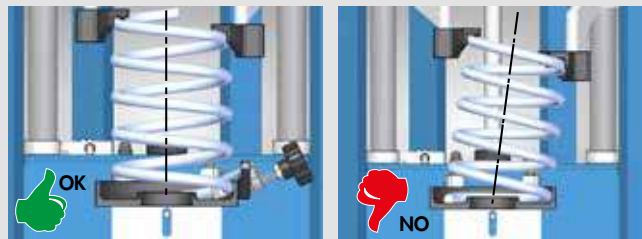

GO CODE **321**
with 1 pcs. 0,4 Kg
PATENTED

G TOOL FOR SHOCK ABSORBER STRUT WITH OVAL PIN

UNIVERSAL

- Ideal for retaining the shock absorber strut during the assembly and disassembly phase of the rear shock absorber upper support. It lets you hold the piston strut up when loosening the fixing nut on the bearing of the support.
- ✓ Suitable for all shock absorbers with oval pin
- ✓ With 2 different sizes per tool: 5x8mm and 6x9mm
- ✓ Safer and easier to handle than locking pliers.

The ends of the tools are slightly elbow-shape beni, thus leaving more room for unscrewing operations



APPLICATION	
VW, Audi, Ford, Opel	



GO CODE **384**
with 1 pcs. 0,2 Kg

G SHOCK ABSORBER TOOLS SET FOR PISTON ROD

- Tool set to counteract the shock absorber's piston rod and, at the same time, to loosen and tighten the retaining nuts on the rod.
- Suitable for many MAC-Pherson suspensions.
- For removing suspensions after clamping the spring.



Using a coupling torque wrench and its set of keys (ring or combination), the nut can be tightened all the way, during assembly, through the default torque.

GO CODE **345**
with 22 pcs. 4,2 Kg

G "GOFIGHTER4000" PNEUMATIC COIL SPRING COMPRESSOR

CE

4 TON

- Universal pneumatic spring compressor, its range covers all kind of vehicle equipped with Mc-Pherson shock absorbers.

ACCESSORI INCLUSI

GOFIGHTER 4000	
FORCE (TON)	4.0
Cylinder stroke (mm)	380
Single plate	✓
Upper floating clamps	✓
Universal bracket	✓
Stem support	✓
High security protection	✓

AIR CONSUMPTION		
	DRY CYCLE CONSUMPTION	CHARGE CYCLE CONSUMPTION
m³/h	0,13	0,07
lt/min	2,17	1,17

NEW SPRING COMPRESSION SYSTEM:

- + Suitable for all kind of spring diameters on the market
- + Capable of working on rightward helical spring
- + Capable of working on leftward helical spring
- + The shock absorber can be blocked on the hydraulic part (bracket function)

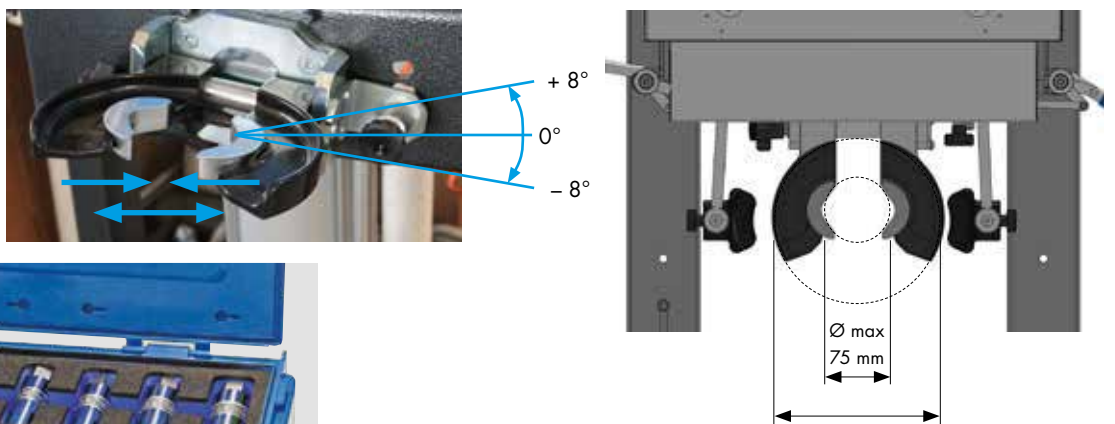

Adjustable for springs from Ø 78 mm to Ø 205 mm and for locking shock absorber stem Ø 75 max

GO CODE **344**
with 1 pcs. 150 Kg
PATENTED

G "GOECO2500" PNEUMATIC COIL SPRING COMPRESSOR 2.5 TON
CE

- Pneumatic spring compressor for passengers' cars, SUV and commercial vehicles.

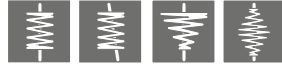

ACCESSORIES INCLUDED
GOECO2500

FORCE (TON)	2.5
Cylinder stroke (mm)	330
Double plate	✓
Fixed upper brackets	✓
Vice Ø 40-60 mm	✓

UPGRADE OPTION

	GO341	Bracket small Ø78÷130 mm	
	GO342	Bracket medium Ø105÷185 mm	
	GO343	Bracket medium Ø125÷205 mm	
	GO339	Bracket leftwards Ø105÷185 mm	
	GO313	Upper floating clamps	

AIR CONSUMPTION

	DRY CYCLE CONSUMPTION	CHARGE CYCLE CONSUMPTION
m³/h	0,11	0,04
lt/min	1,83	0,67



GO CODE **325**
T with 2 pcs. Kg 65 Kg
§ PATENTED



G "GOMAX2000" PNEUMATIC COIL SPRING COMPRESSOR 2 TON
CE

- Pneumatic spring compressor from passenger cars to SUVs.



ACCESSORIES INCLUDED
GOMAX2000

FORCE (TON)	2.0
Cylinder stroke (mm)	330
Piastra telaio singola	✓
Adjustable upper gripper jaws	✓
Vice Ø 40-60 mm	✓
Bracket small Ø78÷130 mm	✓
Bracket medium Ø105÷185	✓

		Stem support	✓
		High security protection	✓
		Transport module with wheels	✓

AIR CONSUMPTION

	DRY CYCLE CONSUMPTION	CHARGE CYCLE CONSUMPTION
m³/h	0,08	0,03
lt/min	1,33	0,5

UPGRADE OPTION

	GO343	Bracket large Ø125÷205 mm	
	GO339	Bracket leftwards Ø105÷185 mm	



GO CODE **320**
T with 4 pcs. Kg 105 Kg
§ PATENTED

G "GOMAX3000" PNEUMATIC COIL SPRING COMPRESSOR 3 TON
CE

- Pneumatic spring compressor from passenger cars to transporters.

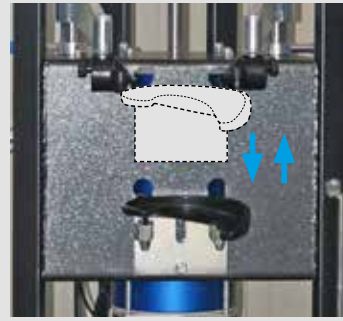
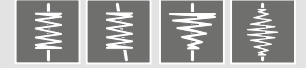

AIR CONSUMPTION

	DRY CYCLE CONSUMPTION	CHARGE CYCLE CONSUMPTION
m³/h	0,16	0,1
lt/min	2,67	1,67

GO CODE **330**
T with 5 pcs. Kg 120 Kg
§ PATENTED

ACCESSORIES INCLUDED
GOMAX3000

FORCE (TON)	3.0
Cylinder stroke (mm)	330
Double plate	✓

		Cylinder stroke	✓
		Vice Ø 40-60 mm	✓
		Bracket small Ø78÷130 mm	✓
		Bracket medium Ø105÷185 mm	✓
		Stem support	✓
		High security protection	✓
		Transport module with wheels	✓
		Mirror with swan neck, magnetic	✓

	GO343	Staffa grande Ø125÷205 mm	
	GO339	Staffa sinistrorsa Ø105÷185 mm	

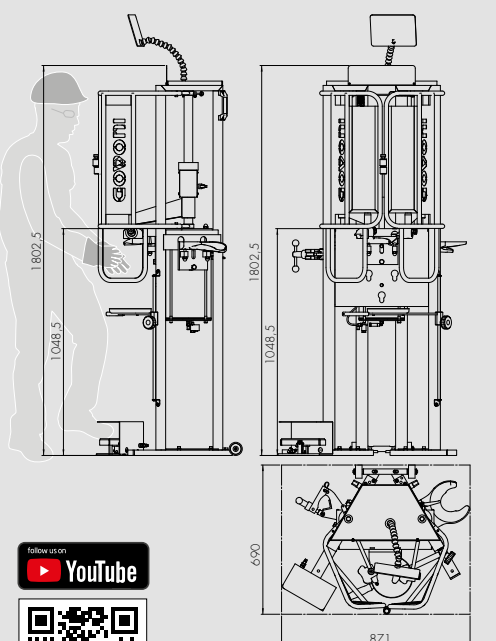

G TWO SPEED HAND PUMP WITH MOBIL RAM RANGE HYDRAULIC PRESSES

MOBIL RAM RANGE | TWO SPEED | CE

- New series of manual double speed hydraulic hand pump with mobile ram.
- Thanks to the adjustable ram device, it is possible to make different operations on one piece when the removal or the same result too difficult and expensive.
- ✓ All the presses have a calibration valve and gauge.
- ✓ All the machines are supplied with nr. 2 "V" blocks and nr. 1 plate.
- ✓ The model with power of 30 and 50 ton are supplied with a winch for the hoisting of the working table.
- ✓ All the ram are in special steel treated and chromium plated.
- ✓ The machines are designed and manufactured as per the last CE directives.

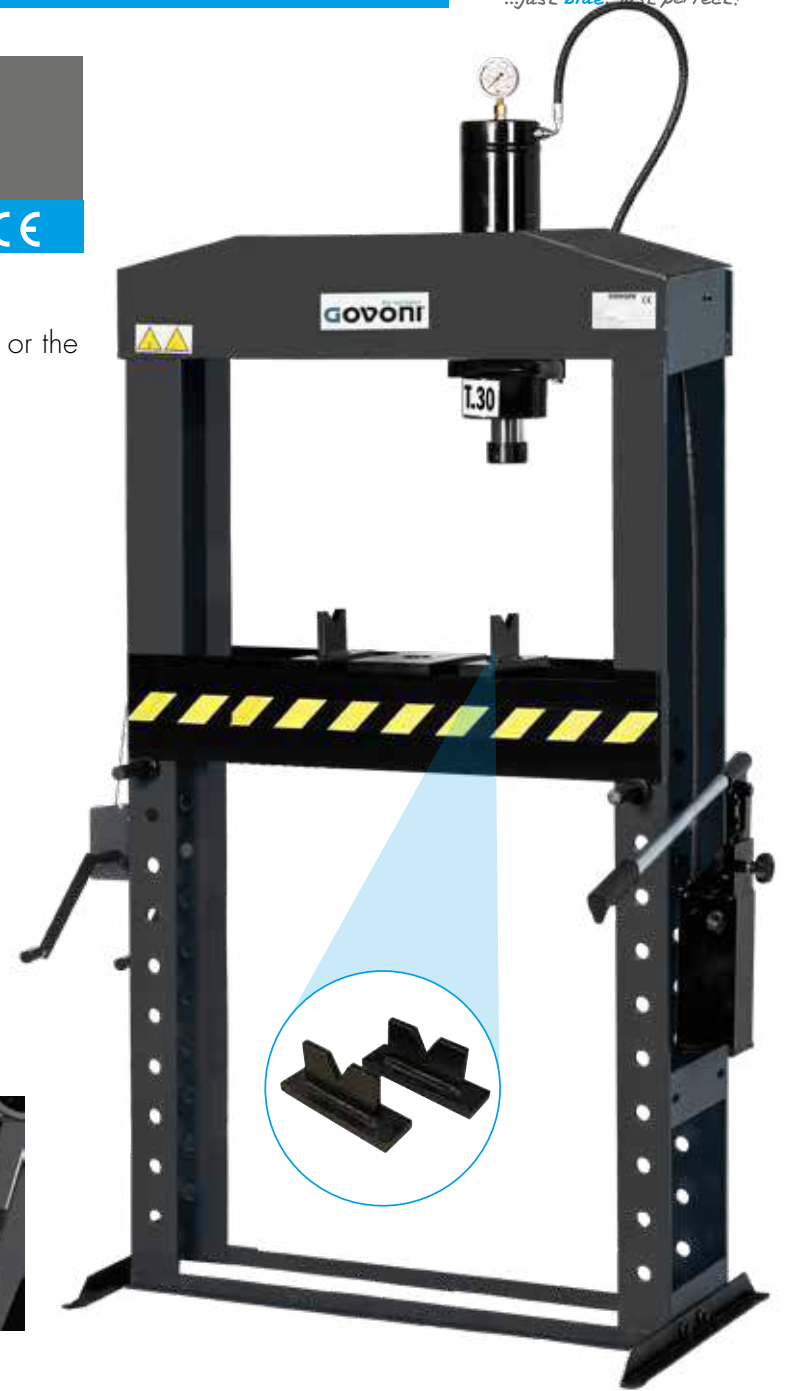
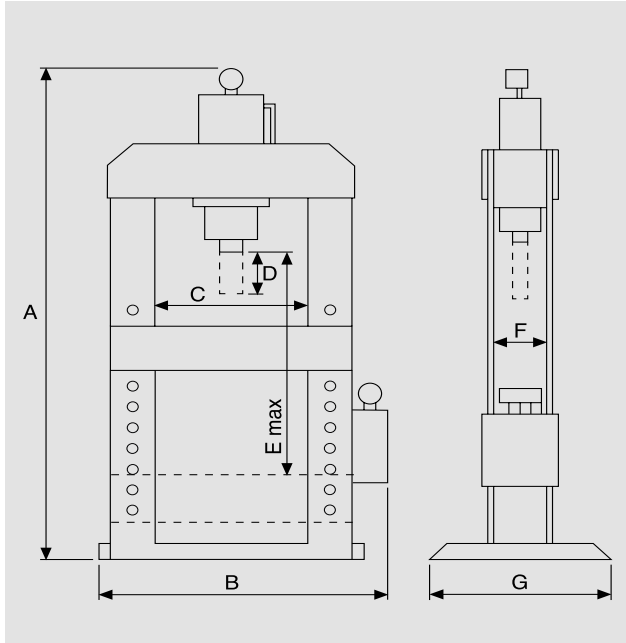

+ **PLUS**
The model with power of 30 and 50 ton are supplied with a winch for the hoisting of the working table.

+ **PLUS**
All the machines are supplied with nr. 2 "V" blocks and nr. 1 plate.

	CODE	CAPACITY	A (mm)	B (mm)	C (mm)	D (mm)	E (mm)	F (mm)	G (mm)	Ø PISTON (mm)	COMP.	WEIGHT
MOBILE RAM	GO1410	20	2000	1000	620	180	1100	150	500	45	1 pcs	160 Kg
	GO1411	30	2130	1200	700	200	1100	180	650	50	1 pcs	255 Kg
	GO1412	50	2300	1300	800	200	1050	180	750	60	1 pcs	395 Kg

G SOLLEVATORI IDRAULICI A CARRELLO CON RUOTE IN VULKOLLAN®

CE

+ **PLUS DOUBLE WHEELS**
double ball bearing!

- New hydraulic trolley jacks designed and manufactured for an easy moving of vehicles on floor with grates.
- Thanks to the double front vulkollan wheels, with double ball bearing, these jacks are suitable for using in case of assistance.

+ **INCLUDED**
Supplied with an automatic end stroke safety valve and removable handle.

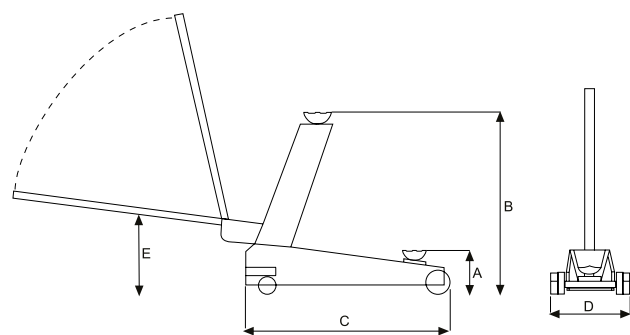

CODE	WHEEL	CAPACITY ON THE PLATE	CAPACITY ON THE VEHICLES	A (mm)	B (mm)	C (mm)	D (mm)	E (mm)	COMP.	WEIGHT
GO1460	SINGLE WHEEL	1,5	2,5	120	540	675	325	160	1pz	32 Kg
GO1461	SINGLE WHEEL	2,5	4	130	550	720	335	170	1pz	37 Kg
GO1462	DOUBLE WHEELS	1,5	2,5	120	540	705	370	160	1pz	40 Kg
GO1463	DOUBLE WHEELS	2,5	4	130	550	750	400	170	1pz	40 Kg



**MOBILE LIFTING TABLE,
1.500 KG**

UNIVERSAL



NEW

Universal lifting table for electric-car batteries; it's also perfect for lifting and moving engines, automatic gearboxes, chassis components.

1. extendable range handle (incl. 2x handwheel for fixation)
2. platform extendable (extension and access to the centre) (incl. handle and 2x handwheel for fixation)
3. platform laterally adjustable by 40 mm (access for adjustment from left and right without the need to move the table out from the vehicle underbody)
4. inclination of the platform ±3% adjustable (compensation to lifting platform/floor inclination)
5. platform with M8 threaded housings for support adapters or special solutions (see

- p. 4 "Upgrade option") (GO1504)
6. lifting and lowering via foot pedal + unlocking head on handle (with remote control see p. 4 "Upgrade option") GO1500TR)
7. safety lock prevents unintentional lowering
8. large wheels = easy handling/positioning
9. housing system for transport with forklift truck

Suitable for all types of batteries UP TO 1500 kg (image of the battery from demonstration purposes and not included in the supply)



- Aside from lifting electric-car batteries, this product is also perfect for: lifting and moving engines, automatic gearboxes, chassis components
- It is powered by compressed air.
- It allows convenient battery installation or removal, thanks to the sliding cover that can be opened.
- Its high ground clearance makes it compatible with all workshop cranes on the market.
- It is easy to operate and tilt with self-explanatory operations.
- The top table is extendable and tiltable by means of a mechanical screw, it also has holes with M8 thread, on which all types of supports or accessories can be mounted: special hooks, special brackets, plastic caps, protective mats for battery packs.

Technical data

- Extendable table (opening) 200 mm
- Tilting table (angle) ±3°
- Shifting table (R & L) ±30 mm
- Extendable range handle 225 mm
- Fork housing incl.
- Max capacity 1.500 kg
- Lifting time 80 s (no load) / 150 s (full load)
- Lowering time 70 s (no load) / 15 s (full load)
- Air power supply 6/8 bar



+ UPGRADE OPTION +
GO1502 Protective roller blind for the scissor lift.
This roller blind can also be customized on request**!
**Personalisation of the protective roller blind is associated with additional costs.

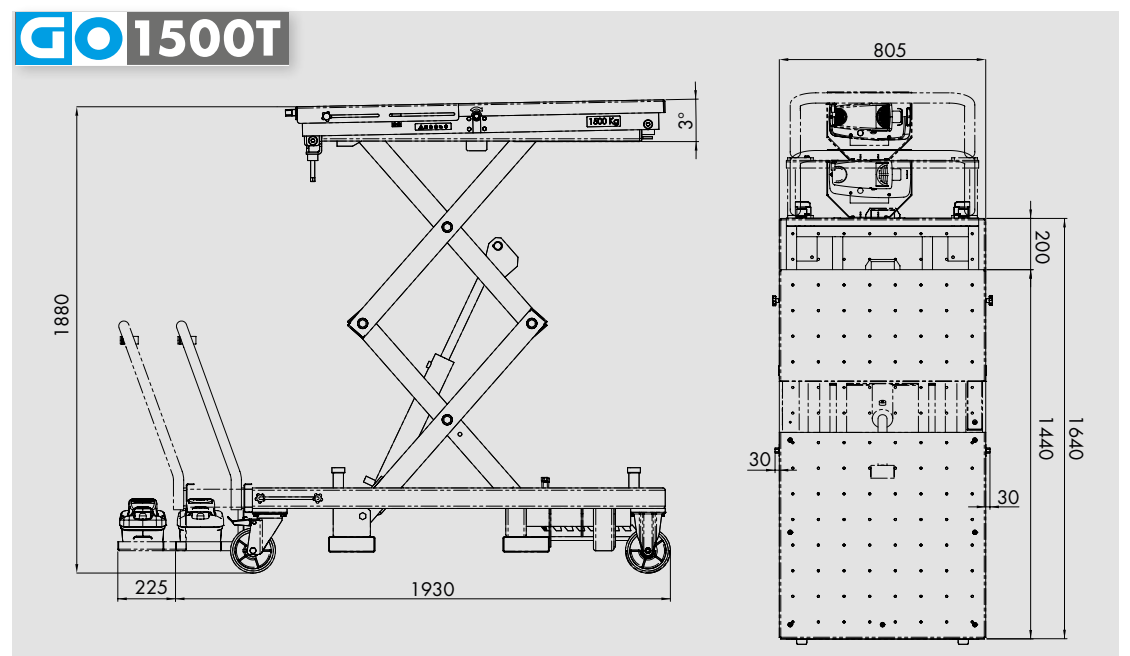

CODE	MAX CAPACITY Kg	OPENING TABLE (OPEN)	TILTING TABLE (ANGLE)	TILTING TABLE (RIGHT & LEFT)	EXTENDABLE HANDLE	FORK HOUSING	TIME TO GO UP	TIME TO GO DOWN	POWER SUPPLY	REMOTE CONTROL	WEIGHT
GO1500T	1500	200mm	±3°	±30mm	225 mm	incluso	80 s (no load) 150 s (full load)	70 s (no load) 15 s (full load)	6/8 bar	-	430 kg
GO1500TR	1500	200mm	±3°	±30mm	225 mm	incluso	80 s (a vuoto) 150 s (full load)	70 s (a vuoto) 15 s (full load)	6/8 bar	include	430 kg

G BATTERY LIFT ACCESSORIES KIT NEW

M8 M10

- Required to hold battery pack on the platform
- The components fits perfectly to the different types of batteries, taking into consideration the possible specifications of the manufacturer
- Slotted holes in the foot allow an easy changing/moving of the platform
- The support columns are height-adjustable and have a thread for screwing the rubbers/spacers

Technical data

- Support foot length 200 mm
- Minimum height 215 mm
- Maximum height 315 mm
- Usable key for upper pin SW32 mm
- Threads used for top fixing M8
- Maximum capacity for each support 100 Kg



COMPONENTS

6 x	support leg with fixing screw M8 and M10
3 x	connecting crosspieces L=300 mm
6 x	extension for rubber bearing AG M8 x IG M8
6 x	extension for rubber bearing AG M10 x IG M8
6 x	rubber support AG M8

+ **PLUS**
Used for platforms with M8 and M10 threaded holes!

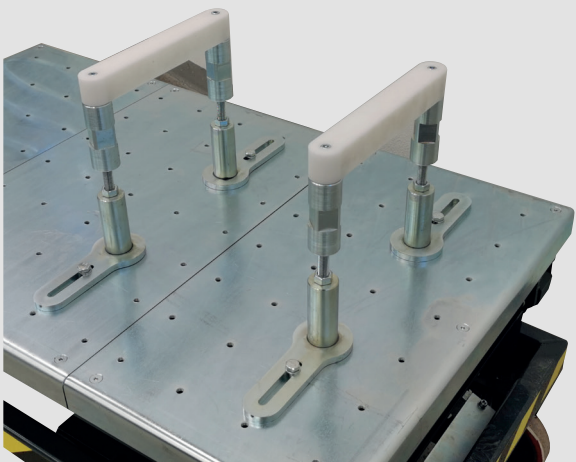

GO CODE **1503**
with 26 pcs. 18,5 Kg

G + UPGRADE OPTION + RUBBER SUPPORT ADAPTER KIT NEW M10



To be screwed to the platform (for battery insulation).

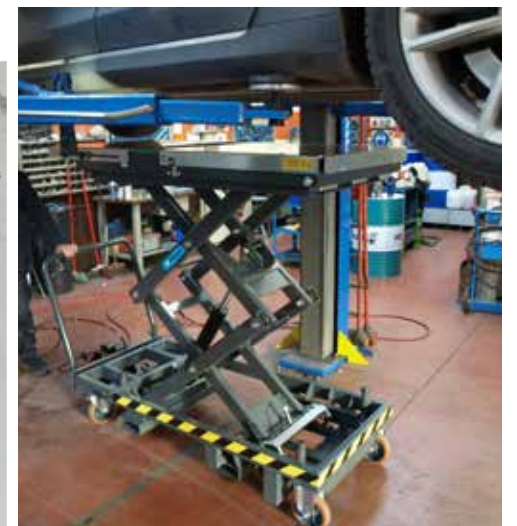
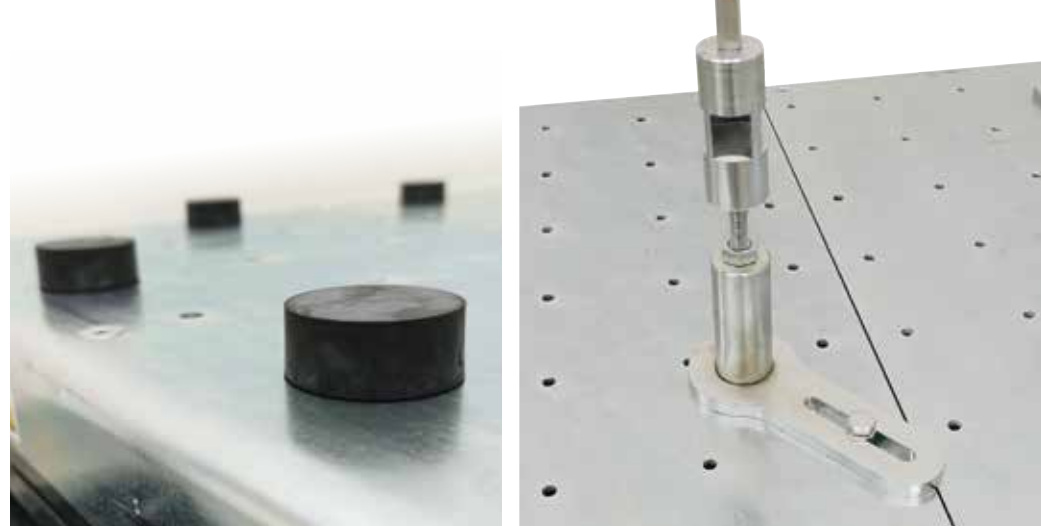

GO CODE **1501**
with 15 pcs. 2,5 Kg



G + UPGRADE OPTION + RUBBER SUPPORT ADAPTER KIT NEW M8



GO CODE **1504**
with 12 pcs. 2 Kg



G MULTIFUNCTIONAL DEVICE FOR TESTING ELECTRONIC COMPONENTS UP TO 24V

CE UNIVERSAL



NEW

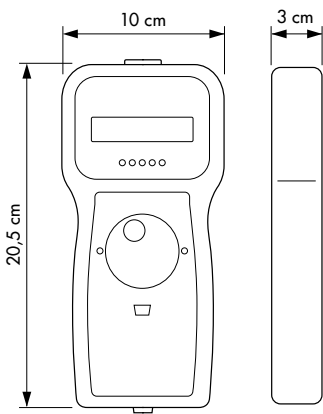

- Indispensable for checking the analog and PWM signals of the sensors and also for activating various types of electromechanical actuators.
- A single instrument that contains infinite functions: the test and diagnosis capabilities of SPECTRUMpro are so broad and diversified that they have no comparison with any other device on the market.

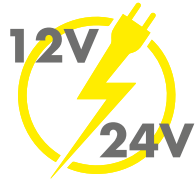

+ **INTUITIVE**
automatically recognizes the voltage at which it is connected



DISPLAY
Two-line alphanumeric screen

KNOB CONTROL
Multifunction knob with digital encoder

USB PORT
for PC connection (software update and application programs)

SUPPLY VOLTAGE
9-28Vdc directly from the battery

CONNECTION
Reverse and voltage peak protection.
Overcurrent protection through external fuses



+ **PLUS**
The tests can be carried out both with the component mounted on the vehicle and on the "bench".



GO CODE **2100PRO**
with 14 pcs. **Kg** 3,5 Kg

G **+** **UPGRADE OPTION** **+**
DOCKING STATION **NEW**

- Complete with removable cover, with retractable hanging hook.
- Ideal workstation for bench operations.



G **+** **UPGRADE OPTION** **+**
COVER **NEW**

- Ergonomic cover, with retractable hanging hook.
- Practical and transportable, to be hooked to the hood of the vehicle or other support points, allowing hands-free interventions.



GO CODE **2115**
with 2 pcs. **Kg** 2 Kg



GO CODE **2116**
with 1 pcs. **Kg** 0,5 Kg



Distribuito da:

Blank space for distributor information.

Blank space for distributor information.